



# SWIMMING POOL HEAT PUMP

## Installation & Instruction Manual



**IMPORTANT NOTE:**

Thank you very much for purchasing our product. Before using your unit, please read this manual carefully and keep it for future reference.



# CONTENTS

1. FOREWORD .....	1
1.1. Read the Manual Before Operation .....	1
1.2. The Symbol Description of The Device .....	6
1.3. Statement .....	6
1.4. Safety Factors .....	7
2. OVER VIEW OF THE UNIT .....	8
2.1. Accessories Supplied With The Unit .....	8
2.2. Dimensions of The Unit .....	9
2.3. Main Parts of The Unit .....	10
2.4. Parameter of the Unit .....	14
3. INSTALLATION AND CONNECTION .....	16
3.1. Transportation .....	16
3.2. Notice Before Installation .....	16
3.3. Installation Instruction .....	17
3.4. Trial Running After Installation .....	20
4. WIRE CONTROLLER OPERATION GUIDANCE .....	21
4.1. Wire Control Panel Diagram .....	21
4.2. Key Operating Instruction .....	23
4.3. System Status Parameter Query .....	25
4.5. Wi-Fi Settings .....	26
5. MAINTENANCE AND WINTERZING .....	40
5.1. Maintenance .....	40
5.2. Disassembly Guidelines .....	40
5.3. Winterizing .....	44

# **1. FOREWORD**

## **1.1. Read the Manual Before Operation**

### **WARNING**

Do not use means to accelerate the defrosting process or to clean, other than those recommended by the manufacturer. The appliance shall be stored in a room without continuously operating ignition sources (for example: open flames, an operating gas appliance or an operating electric heater).

Do not pierce or burn.

Be aware that refrigerants may not contain an odour.

### ***Initial safety checks shall include:***

- ① That capacitors are discharged: this shall be done in a safe manner to avoid possibility of sparking;
- ② That no live electrical components and wiring are exposed while charging, recovering or purging the system;
- ③ That there is continuity of earth bonding.

### ***Checks to the area***

Prior to beginning work on systems containing flammable refrigerants, safety checks are necessary to ensure that the risk of ignition is minimized. For repair to the refrigerating system, the following precautions shall be completed prior to conducting work on the system.

### ***Work procedure***

Work shall be undertaken under a controlled procedure so as to minimize the risk of a flammable gas or vapour being present while the work is being performed.

### ***General work area***

All maintenance staff and others working in the local area shall be instructed on the nature of work being carried out. Work in confined spaces shall be avoided.

### ***Checking for presence of refrigerant***

The area shall be checked with an appropriate refrigerant detector prior to and during work, to ensure the technician is aware of potentially flammable atmospheres. Ensure that the leak detection equipment being used is suitable for use with flammable refrigerants, i.e. non-sparking, adequately sealed or intrinsically safe.

### ***Presence of fire extinguisher***

If any hot work is to be conducted on the refrigerating equipment or any associated parts, appropriate fire extinguishing equipment shall be available to hand. Have a dry powder or CO<sub>2</sub> fire extinguisher adjacent to the charging area.

### ***No ignition sources***

No person carrying out work in relation to a refrigeration system which involves exposing any pipe work that contains or has contained flammable refrigerant shall use any sources of ignition in such a manner that it may lead to the risk of fire or explosion. All possible ignition sources, including cigarette smoking, should be kept sufficiently far away from the site of installation, repairing, removing and disposal, during which flammable refrigerant can possibly be released to the surrounding space. Prior to work taking place, the area around the equipment is to be surveyed to make sure that there are no flammable hazards or ignition risks. "No Smoking" signs shall be displayed.

### ***Ventilated area***

Ensure that the area is in the open or that it is adequately ventilated before breaking into the system or conducting any hot work. A degree of ventilation shall continue during the period that the work is carried out. The ventilation should safely disperse any released refrigerant and preferably expel it externally into the atmosphere.

### ***Checks to the refrigeration equipment***

Where electrical components are being changed, they shall be fit for the purpose and to the correct specification. At all times the manufacturer's maintenance and service guidelines shall be followed. If in doubt consult the manufacturer's technical department for assistance.

The following checks shall be applied to installations using flammable refrigerants:

- ① The charge size is in accordance with the room size within which the refrigerant containing parts are installed;
- ② The ventilation machinery and outlets are operating adequately and are not obstructed;
- ③ If an indirect refrigerating circuit is being used, the secondary circuit shall be checked for the presence of refrigerant;
- ④ Marking to the equipment continues to be visible and legible. Markings and signs that are illegible shall be corrected;
- ⑤ Refrigeration pipe or components are installed in a position where they are unlikely to be exposed to any substance which may corrode refrigerant containing components, unless the components are constructed of materials which are inherently resistant to being corroded or are suitably protected against being so corroded.

### ***Repairs to sealed components***

- During repairs to sealed components, all electrical supplies shall be disconnected from the equipment being worked upon prior to any removal of sealed covers, etc. If it is absolutely necessary to have an electrical supply to equipment during servicing, then a permanently operating form of leak detection shall be located at the most critical point to warn of a potentially hazardous situation.
- Particular attention shall be paid to the following to ensure that by working on electrical components, the casing is not altered in such a way that the level of protection is affected. This shall include damage to cables, excessive number of connections, terminals not made to original specification, damage to seals, incorrect fitting of glands, etc.

- Ensure that the apparatus is mounted securely.  
Ensure that seals or sealing materials have not degraded to the point that they no longer serve the purpose of preventing the ingress of flammable atmospheres. Replacement parts shall be in accordance with the manufacturer's specifications.

#### ***Repair to intrinsically safe components***

- Do not apply any permanent inductive or capacitance loads to the circuit without ensuring that this will not exceed the permissible voltage and current permitted for the equipment in use. Intrinsically safe components are the only types that can be worked on while live in the presence of a flammable atmosphere. The test apparatus shall be at the correct rating.
- Replace components only with parts specified by the manufacturer. Other parts may result in the ignition of refrigerant in the atmosphere from a leak.
- NOTE The use of silicon sealant can inhibit the effectiveness of some types of leak detection equipment.
- Intrinsically safe components do not have to be isolated prior to working on them.

#### ***Cabling***

- Check that cabling will not be subject to wear, corrosion, excessive pressure, vibration, sharp edges or any other adverse environmental effects. The check shall also take into account the effects of aging or continual vibration from sources such as compressors or fans.

#### ***Detection of flammable refrigerants***

- Under no circumstances shall potential sources of ignition be used in the searching for or detection of refrigerant leaks. A halide torch (or any other detector using a naked flame) shall not be used.

#### ***Leak detection methods***

- The following leak detection methods are deemed acceptable for systems containing flammable refrigerants.
- Electronic leak detectors shall be used to detect flammable refrigerants, but the sensitivity may not be adequate, or may need re-calibration. (Detection equipment shall be calibrated in a refrigerant-free area.) Ensure that the detector is not a potential source of ignition and is suitable for the refrigerant used. Leak detection equipment shall be set at a percentage of the LFL of the refrigerant and shall be calibrated to the refrigerant employed and the appropriate percentage of gas (25 % maximum) is confirmed.
- Leak detection fluids are suitable for use with most refrigerants but the use of detergents containing chlorine shall be avoided as the chlorine may react with the refrigerant and corrode the copper pipe-work.
- If a leak is suspected, all naked flames shall be removed/extinguished.
- If a leakage of refrigerant is found which requires brazing, all of the refrigerant shall be recovered from the system, or isolated (by means of shut off valves) in a part of the system remote from the leak. Oxygen free nitrogen (OFN) shall then be purged through the system both before and during the brazing process.

### ***Removal and evacuation***

When breaking into the refrigerant circuit to make repairs – or for any other purpose – conventional procedures shall be used. However, it is important that best practice is followed since flammability is a consideration. The following procedure shall be adhered to:

- ① Remove refrigerant;
- ② Purge the circuit with inert gas;
- ③ Evacuate;
- ④ Purge again with inert gas;
- ⑤ Open the circuit by cutting or brazing.

The refrigerant charge shall be recovered into the correct recovery cylinders. The system shall be “flushed” with OFN to render the unit safe. This process may need to be repeated several times. Compressed air or oxygen shall not be used for this task.

Flushing shall be achieved by breaking the vacuum in the system with OFN and continuing to fill until the working pressure is achieved, then venting to atmosphere, and finally pulling down to a vacuum. This process shall be repeated until no refrigerant is within the system. When the final OFN charge is used, the system shall be vented down to atmospheric pressure to enable work to take place. This operation is absolutely vital if brazing operations on the pipework are to take place.

Ensure that the outlet for the vacuum pump is not close to any ignition sources and there is ventilation available.

### ***Charging procedures***

In addition to conventional charging procedures, the following requirements shall be followed:

- ① Ensure that contamination of different refrigerants does not occur when using charging equipment. Hoses or lines shall be as short as possible to minimize the amount of refrigerant contained in them. Cylinders shall be kept upright.
- ② Ensure that the refrigeration system is earthed prior to charging the system with refrigerant.
- ③ Label the system when charging is complete (if not already).
- ④ Extreme care shall be taken not to overfill the refrigeration system. Prior to recharging the system it shall be pressure tested with OFN. The system shall be leak tested on completion of charging but prior to commissioning. A follow up leak test shall be carried out prior to leaving the site.

### ***Decommissioning***

Before carrying out this procedure, it is essential that the technician is completely familiar with the equipment and all its detail. It is recommended good practice that all refrigerants are recovered safely. Prior to the task being carried out, an oil and refrigerant sample shall be taken in case analysis is required prior to re-use of reclaimed refrigerant. It is essential that electrical power is available before the task is commenced.

- ① Become familiar with the equipment and its operation.
- ② Isolate system electrically.
- ③ Before attempting the procedure ensure that:
  - Mechanical handling equipment is available, if required, for handling refrigerant cylinders;
  - All personal protective equipment is available and being used correctly;

- The recovery process is supervised at all times by a competent person;
- Recovery equipment and cylinders conform to the appropriate standards.
- ④ Pump down refrigerant system, if possible.
- ⑤ If a vacuum is not possible, make a manifold so that refrigerant can be removed from various parts of the system.
- ⑥ Make sure that cylinder is situated on the scales before recovery takes place.
- ⑦ Start the recovery machine and operate in accordance with manufacturer's instructions.
- ⑧ Do not overfill cylinders. (No more than 80 % volume liquid charge).
- ⑨ Do not exceed the maximum working pressure of the cylinder, even temporarily.
- ⑩ When the cylinders have been filled correctly and the process completed, make sure that the cylinders and the equipment are removed from site promptly and all isolation valves on the equipment are closed off.
- ⑪ Recovered refrigerant shall not be charged into another refrigeration system unless it has been cleaned and checked.

### ***Labeling***

Equipment shall be labeled stating that it has been decommissioned and emptied of refrigerant. The label shall be dated and signed. Ensure that there are labels on the equipment stating the equipment contains flammable refrigerant.

### ***Recovery***

When removing refrigerant from a system, either for servicing or decommissioning, it is recommended good practice that all refrigerants are removed safely. When transferring refrigerant into cylinders, ensure that only appropriate refrigerant recovery cylinders are employed. Ensure that the correct number of cylinders for holding the total system charge are available. All cylinders to be used are designated for the recovered refrigerant and labeled for that refrigerant (i.e. special cylinders for the recovery of refrigerant). Cylinders shall be complete with pressure relief valve and associated shut-off valves in good working order. Empty recovery cylinders are evacuated and, if possible, cooled before recovery occurs.

The recovery equipment shall be in good working order with a set of instructions concerning the equipment that is at hand and shall be suitable for the recovery of flammable refrigerants.

In addition, a set of calibrated weighing scales shall be available and in good working order.

Hoses shall be complete with leak-free disconnect couplings and in good condition. Before using the recovery machine, check that it is in satisfactory working order, has been properly maintained and that any associated electrical components are sealed to prevent ignition in the event of a refrigerant release. Consult manufacturer if in doubt.







The recovered refrigerant shall be returned to the refrigerant supplier in the correct recovery cylinder, and the relevant Waste Transfer Note arranged. Do not mix refrigerants in recovery units and especially not in cylinders.

If compressors or compressor oils are to be removed, ensure that they have been evacuated to an acceptable level to make certain that flammable refrigerant does not remain within the lubricant. The evacuation process shall be carried out prior to returning the compressor to the suppliers. Only electric heating to the compressor body shall be employed to accelerate this process. When oil is drained from a system, it shall be carried out safely.



## 1.2. The Symbol Description of The Device

The precautions listed here are divided into the following types. They are quite important, so be sure to follow them carefully. Meanings of DANGER, WARNING, CAUTION and NOTE symbols.

Symbols	Meaning	Description
	<b>WARNING</b>	The symbol shows that this appliance uses a flammable refrigerant. If the refrigerant is leaked and exposed to an external ignition source, there is a risk of fire.
	<b>WARNING</b>	All information marked with this symbol is important and should be viewed carefully.
	<b>WARNING</b>	This symbol shows that there might be an electric shock if the appliance still connects the power cleaning, examination and repair.
	<b>CAUTION</b>	This symbol shows anti-freezing protection. It is necessary to prevent the freezing of heat exchanger or water pipes, the power of unit can not be shut off in the ambient temperature lower than 2°C. All the water in the unit and plumbing system must be drained out if the unit will be turned off for a long time.
	<b>CAUTION</b>	This symbol shows that the operation manual should be read carefully.
	<b>CAUTION</b>	This symbol shows that a service personnel should be handling this equipment with reference to the installation manual.
	<b>CAUTION</b>	This symbol shows that information is available such as the operating manual or installation manual.

## 1.3. Statement

To keep users under safe working condition and property safety, please follow the instructions below:

- ① Wrong operation may result in injury or damage;
- ② Please install the unit in compliance with local laws, regulations and standards;
- ③ Confirm power voltage and frequency;
- ④ The unit is only used with grounding sockets;
- ⑤ Independent switch must be offered with the unit.

## 1.4. Safety Factors

The following safety factors need to be considered:

- ① Please read the following warnings before installation;
- ② Be sure to check the details that need attention, including safety factors;
- ③ After reading the installation instructions, be sure to save them for future reference.

### **WARNING**

Make sure that the unit is installed safely and reliably.

- If the unit is not secure or not installed, it may cause damage. The minimum support weight required for installation is  $21\text{g}/\text{mm}^2$
- If the unit was installed in a closed area or limited space, please consider the size of room and ventilation to prevent suffocation caused by refrigerant leakage.

① Use a specific wire and fasten it to terminal block so that the connection will prevent pressure from being applied to parts.

② Wrong wiring will cause fire.

Please connect power wire accurately according to wiring diagram on the manual to avoid burnout of the unit or fire.

③ Be sure to use correct material during installing.

Wrong parts or wrong materials may result in fire, electric shock, or falling of the unit.

④ Install on the ground safely, please read installation instructions.

Improper installation may result in fire, electric shock, falling of the unit, or water leaking.

⑤ Use professional tools for doing electrical work.

If power supply capacity is insufficient or circuit is not completed, it may cause fire or electric shock.

⑥ The unit must have grounding device.

If power supply does not have grounding device, be sure not to connect the unit.

⑦ The unit should be only removed and repaired by professional technician.

Improper movement or maintenance of the unit may cause water leakage, electric shock, or fire. Please find a professional technician to do.

⑧ Don't unplug or plug power during operation. It may cause fire or electric shock.

⑨ Don't touch or operate the unit when your hands are wet. It may cause fire or electric shock.

⑩ Don't place heaters or other electrical appliances near the power wire. It may cause fire or electric shock.

⑪ The water must not be poured directly from the unit. Do not let water to permeate into the electrical components.

### **WARNING**

① Do not install the unit in a location where there may be flammable gas.

② If there is flammable gas around the unit, it will cause explosion.

According to the instruction to carry out drainage system and pipeline work. If drainage system or pipeline is defective, water leakage will occur. And it should be disposed immediately to prevent other household products from getting wet and damage.

③ Do not clean the unit while power is on. Turn off power before cleaning the unit. If not it may result in injury from a high-speed fan or electric shock.

- ④ Stop operating the unit once there is a problem or an fault code.  
Please turn off power and stop running the unit. Otherwise it may cause electric shock or fire.
- ⑤ Be careful when the unit is not packed or not installed.  
Pay attention to sharp edges and fins of heat exchanger.
- ⑥ After installation or repair, please confirm refrigerant is not leaking.  
If refrigerant is not enough, the unit will not work properly.
- ⑦ The installation of external unit must be flat and firm.  
Avoid abnormal vibration and noise.
- ⑧ Don't put your fingers into fan and evaporator.  
High speed running fan will result in serious injury.
- ⑨ This device is not designed for people who is physically or mentally weak (including children) and who does not have experience and knowledge of heating and cooling system. Unless it is used under direction and supervision of professional technician, or has received training on the using of this unit. Children must use it under supervision of an adult to ensure that they use the unit safely. If power wire is damaged, it must be replaced by a professional technician to avoid danger.

## 2. OVER VIEW OF THE UNIT

### 2.1. Accessories Supplied With The Unit

After unpacking, please check if you have all the following components.

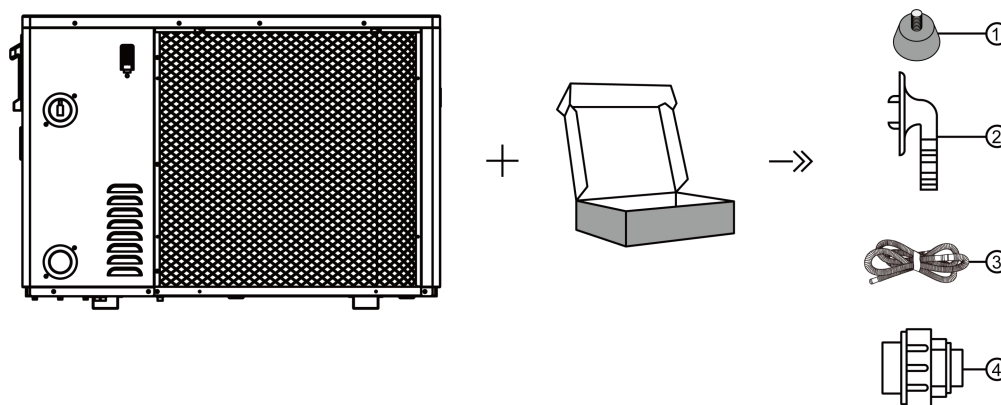

NO.	Components	Quantity	NO.	Components	Quantity
①	Rubber Blanket	4	③	Drain Pipe	1
②	Drain Connector	1	④	Water Pipe Joint	2

## 2.2. Dimensions of The Unit

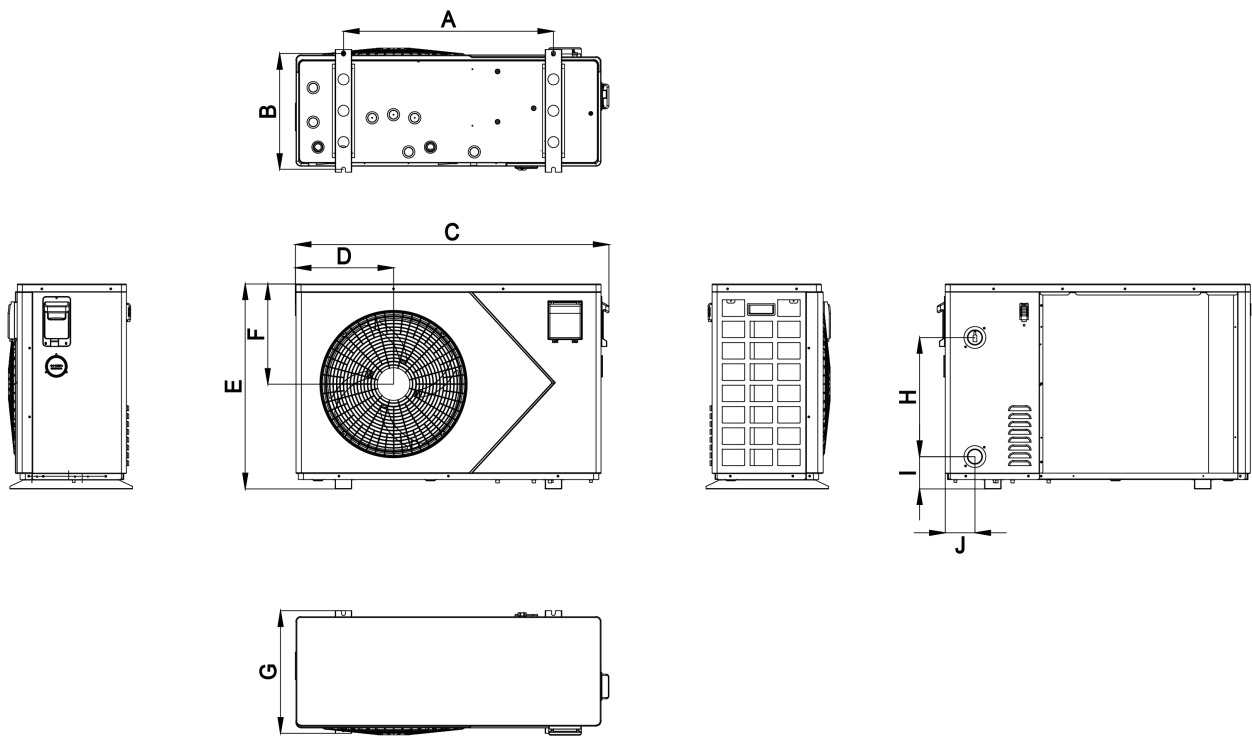

Dimension Unit: (mm)

Model	A	B	C	D	E	F	G	H	I	J
Nova V2 - 09	549	339	910	304	618	307	360	320	98	80
Nova V2 - 15	671	370	1002	314	654	320	391	380	103	95
Nova V2 - 18										
Nova V2 - 21	672	423	1192	358	775	407	447	470	108	126
Nova V2 - 25										
Nova V2 - 28										

## 2.3. Main Parts of The Unit

- Nova V2 - 09

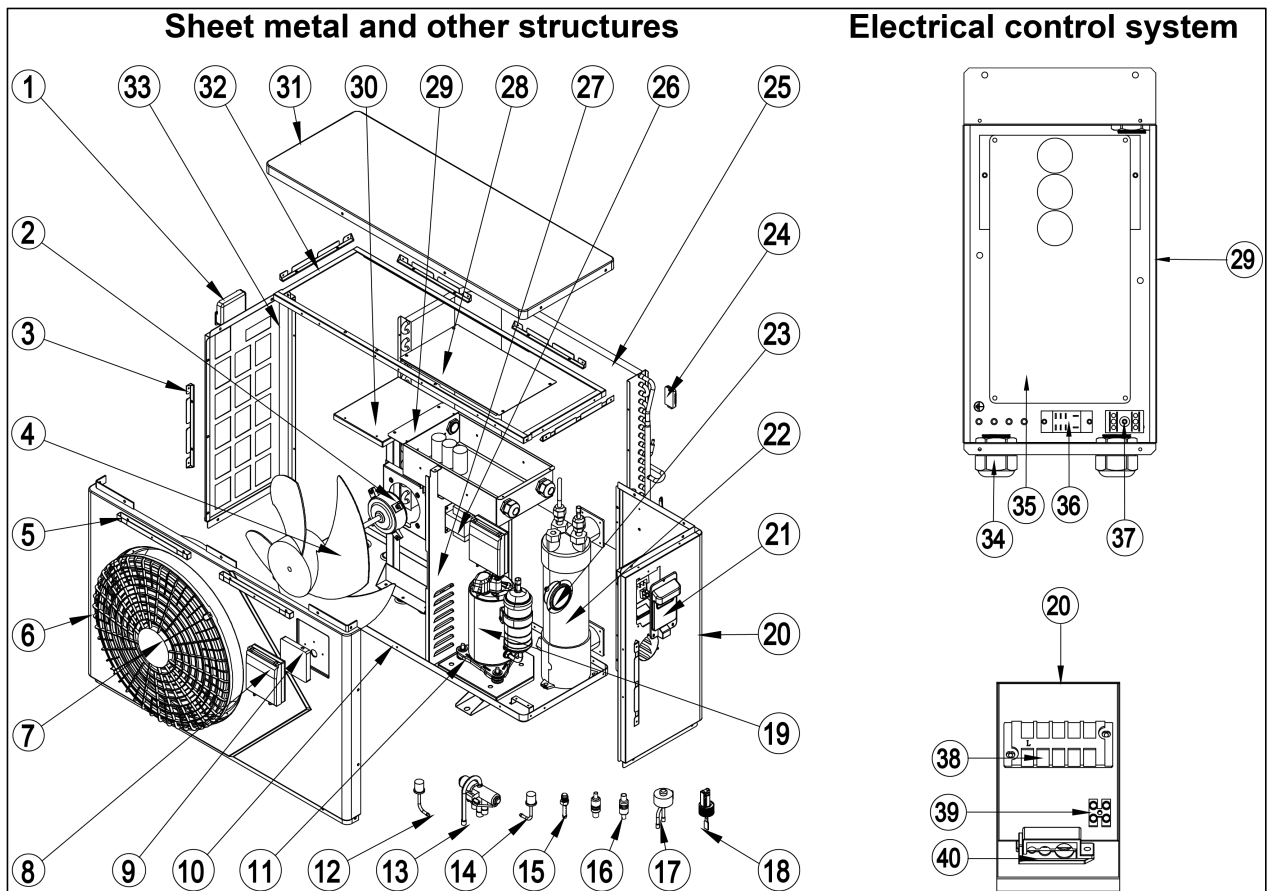

1	Left Handle	15	Needle Valve	29	Electrical Box
2	Fan Motor	16	Refrigerant Filter	30	Fan Motor Support
3	Side Panel Fixed Strip	17	EEV	31	Top Panel
4	Fan Blade	18	Water Flow Switch	32	Top Cover Fixed Strip
5	Front Panel Fixed Strip	19	Compressor	33	Left Panel
6	Front Panel	20	Right Panel Assembly	34	PG Joint
7	Fan Guard	21	Right Handle	35	Main Control Board
8	Waterproof Wire Controller Box	22	Titanium Heat Exchanger	36	Relay
9	Wire Controller	23	High Pressure Gauge	37	Electrical Terminal
10	Chassis Assembly	24	Ambient Temp. Sensor Box	38	5-Pole Terminal Board
11	Compressor Chassis	25	Finned Heat Exchanger	39	2-Pole Terminal Board
12	High Pressure Switch	26	Reactor	40	Wire Fastener
13	4-Way Valve	27	Middle Plate Assembly		
14	Low Pressure Switch	28	Electrical Box Cover		

● Nova V2 - 15/ Nova V2 - 18

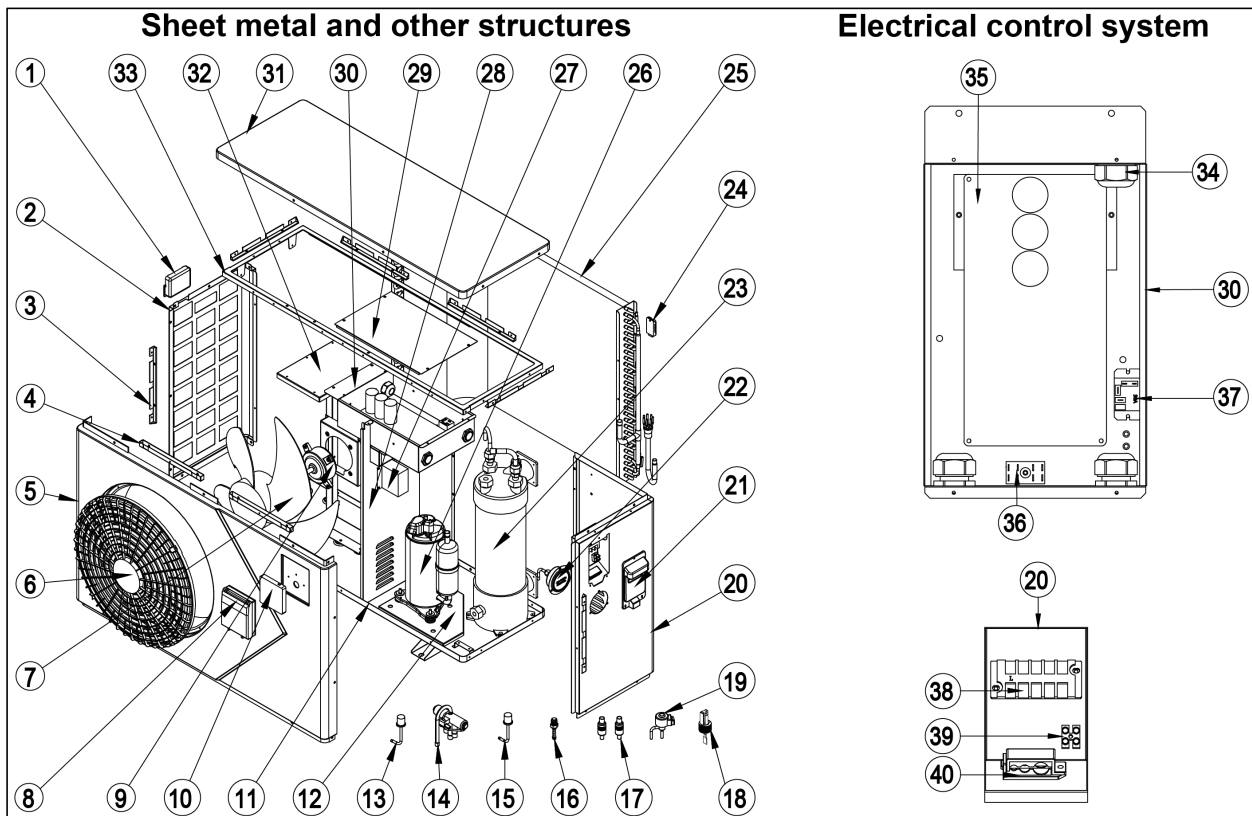

1	Left Handle	15	Low Pressure Switch	29	Electrical Box Cover
2	Left Panel	16	Needle Valve	30	Electrical Box
3	Side Panel Fixed Strip	17	Refrigerant Filter	31	Top Panel
4	Front Panel Fixed Strip	18	Water Flow Switch	32	Fan Motor Support
5	Front Panel	19	EEV	33	Top Cover Fixed Strip
6	Fan Guard	20	Right Panel Assembly	34	PG Joint
7	Fan Blade	21	Right Handle	35	Main Control Board
8	Waterproof Wire Controller Box	22	High Pressure Gauge	36	Electrical Terminal
9	Fan Motor	23	Titanium Heat Exchanger	37	Relay
10	Wire Controller	24	Ambient Temp. Sensor Box	38	5-Pole Terminal Board
11	Chassis Assembly	25	Finned Heat Exchanger	39	2-Pole Terminal Board
12	Compressor Chassis	26	Compressor	40	Wire Fastener
13	High Pressure Switch	27	Reactor		
14	4-Way Valve	28	Middle Plate Assembly		

● Nova V2 - 21

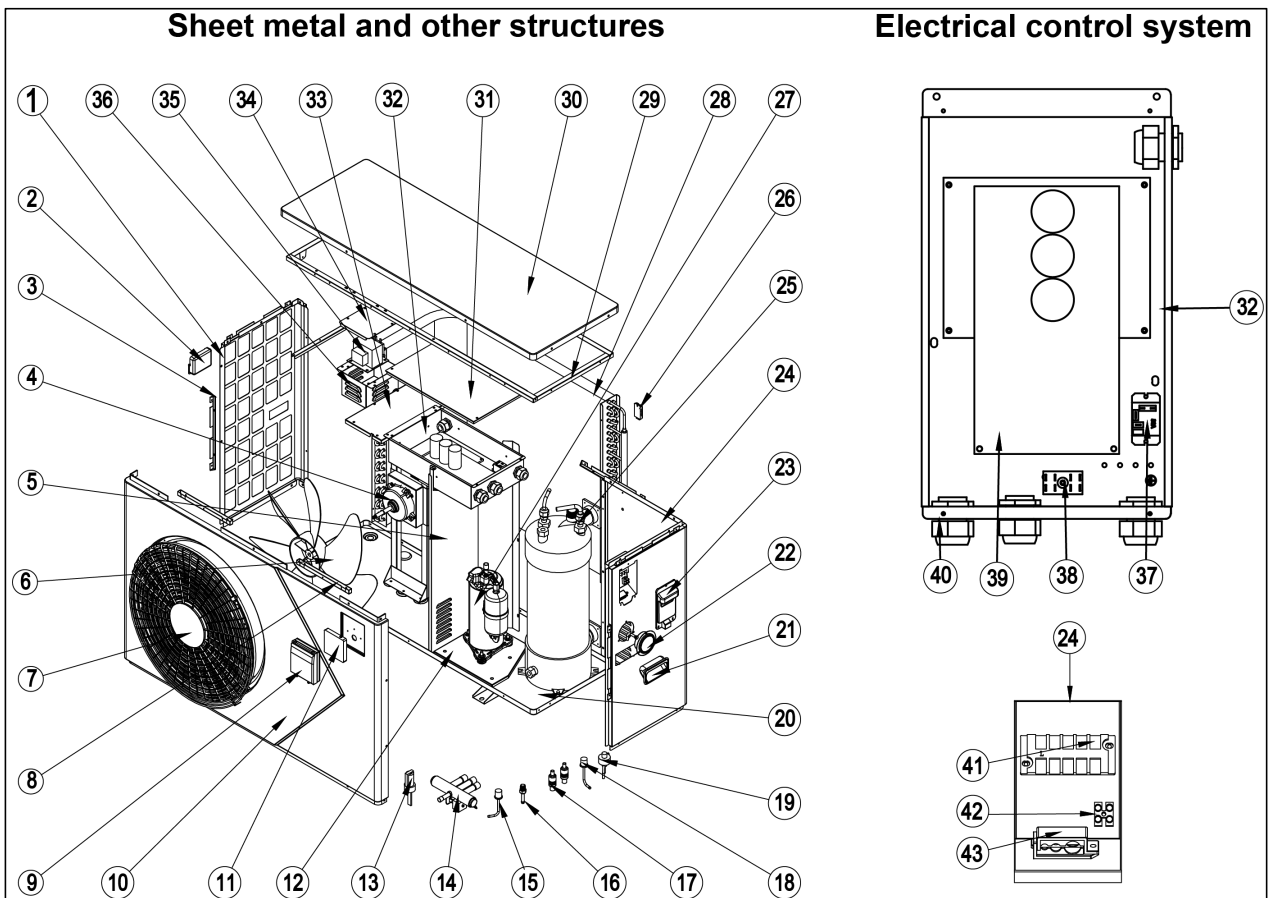

1	Left Panel	16	Needle Valve	31	Electrical Box Cover
2	Left Handle	17	Refrigerant Filter	32	Electrical Box
3	Side Panel Fixed Strip	18	Low Pressure Switch	33	Fan Motor Support
4	Fan Motor	19	EEV	34	Reactor Box Cover
5	Middle Support Plate	20	Chassis Assembly	35	Reactor
6	Fan Blade	21	Right Handle-1	36	Reactor Box
7	Fan Guard	22	Pressure Gauge	37	Relay
8	Front Panel Fixed Strip	23	Right Handle-2	38	Electrical Terminal
9	Waterproof Wire Controller Box	24	Right Panel Assembly	39	Main Control Board
10	Front Panel	25	Titanium Heat Exchanger	40	PG Joint
11	Wire Controller	26	Ambient Temp. Sensor Box	41	5-Pole Terminal Board
12	Compressor Chassis	27	Compressor	42	2-Pole Terminal Board
13	Water Flow Switch	28	Finned Heat Exchanger	43	Wire Fastener
14	4-Way Valve	29	Top Cover Fixed Strip		
15	High pressure switch	30	Top panel		

● Nova V2 - 25/ Nova V2 - 28

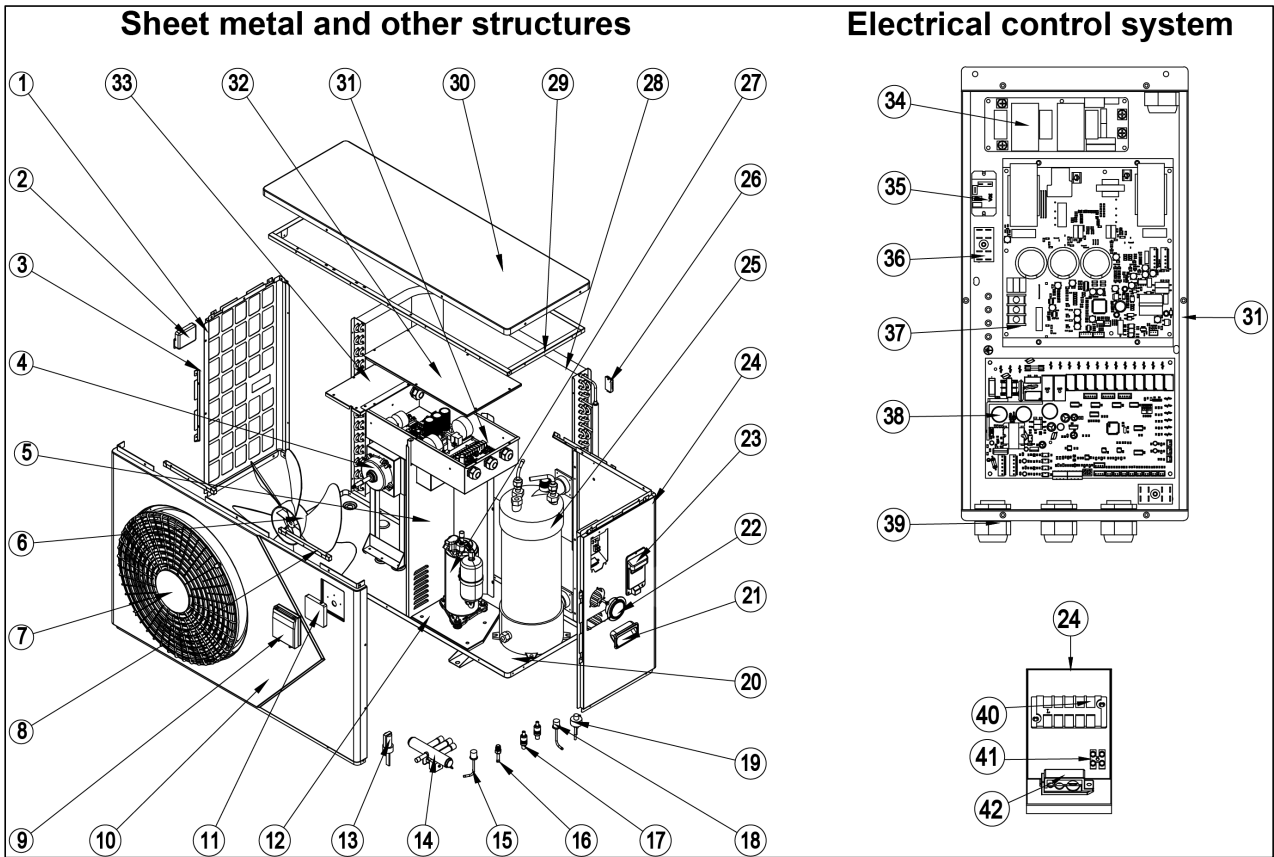

1	Left Panel	15	High Pressure Switch	29	Top Cover Fixed Strip
2	Left Handle	16	Needle Valve	30	Top Panel
3	Side Panel Fixed Strip	17	Refrigerant Filter	31	Electrical Box
4	Fan Motor	18	Low Pressure Switch	32	Electrical Box Cover
5	Middle Support Plate	19	EEV	33	Fan Motor Support
6	Fan Blade	20	Chassis Assembly	34	Wave Filter
7	Fan Guard	21	Right Handle-1	35	Relay
8	Front Panel Fixed Strip	22	Pressure Gauge	36	Electrical Terminal
9	Waterproof Wire Controller Box	23	Right Handle-2	37	Driver Board
10	Front Panel	24	Right Panel Assembly	38	Main Control Board
11	Wire Controller	25	Titanium Heat Exchanger	39	PG Joint
12	Compressor Chassis	26	Ambient Temp. Sensor Box	40	5-pole terminal board
13	Water Flow	27	Compressor	41	2-pole terminal board
14	4-Way Valve	28	Finned Heat Exchanger	42	Wire Fastener



## 2.4. Parameter of the Unit

Model:	Nova V2 - 09	Nova V2 - 15	Nova V2 - 18
<b>Ambient Temperature: (DB/WB) 27°C/24.3°C; Water Inlet/Outlet Temperature: 26°C/28°C.</b>			
Heating Capacity (kW)	1.89~9.22	3.22~15.25	4.15~18.15
Power Input (kW)	0.11~1.29	0.20~2.12	0.26~2.54
COP	16.61~7.15	16.15~7.21	16.21~7.14
<b>Ambient Temperature: (DB/WB) 15°C/12°C; Water Inlet/Outlet Temperature: 26°C/28°C.</b>			
Heating Capacity (kW)	1.32~6.62	2.25~11.05	2.91~13.12
Power Input (kW)	0.15~1.32	0.27~2.19	0.34~2.61
COP	8.80~5.01	8.29~5.05	8.59~5.03
Power Supply	220V-240V~50Hz		
Advised Pool Size (m <sup>3</sup> )	20~40	30~60	35~70
Power Input at 100% (kW)	1.50	2.60	3.27
Running Current at 100% (A)	6.51	11.32	14.21
Heating Water Temp. Range (°C)	9-40		
Cooling Temp. Range (°C)	8-28		
Running Ambient Temp. Range For Heating (°C)	-7~43		
Running Ambient Temp. Range For Cooling (°C)	10~43		
Refrigerant	R32		
Air Side Heat Exchanger	Finned Heat Exchanger		
Water Side Heat Exchanger	Titanium Heat Exchanger		
Water Flow(m <sup>3</sup> /h)	4.0	6.6	7.8
Water Pressure Drop (kPa)	16	17	22
Water Pipe Connection (mm)	48.3		
Noise Level dB(A) at 1m [dB(A)]	42~52	44~54	45~55
Net Dimension LxWxH (mm)	910*360*618	1002*391*654	
Net Weight (kg)	37	46	48
<b>The above data are for reference only, the specific data are subject to actual product.</b>			

Model:	Nova V2 - 21	Nova V2 - 25	Nova V2 - 28
<b>Ambient Temperature: (DB/WB) 27°C/24.3°C; Water Inlet/Outlet Temperature: 26°C/28°C.</b>			
Heating Capacity (kW)	4.34~21.08	4.87~25.37	5.13~28.01
Power Input (kW)	0.27~2.94	0.30~3.60	0.33~4.01
COP	16.34~7.18	16.11~7.05	15.78~6.98
<b>Ambient Temperature: (DB/WB) 15°C/12°C; Water Inlet/Outlet Temperature: 26°C/28°C.</b>			
Heating Capacity (kW)	3.04~14.95	3.41~17.88	3.59~19.61
Power Input (kW)	0.35~2.97	0.40~3.57	0.43~3.93
COP	8.66~5.04	8.54~5.01	8.36~4.99
Power Supply	220V-240V~50Hz		
Advised Pool Size (m <sup>3</sup> )	45~80	55~90	65~100
Power Input at 100% (kW)	3.84	4.20	5.52
Running Current at 100% (A)	16.70	18.28	24.00
Heating Water Temp. Range (°C)	9-40		
Cooling Water Temp. Range (°C)	8-28		
Running Ambient Temp. Range for Heating (°C)	-7~43		
Running Ambient Temp. Range for Cooling (°C)	10~43		
Refrigerant	R32		
Air Side Heat Exchanger	Finned Heat Exchanger		
Water Side Heat Exchanger	Titanium Heat Exchanger		
Water Flow (m <sup>3</sup> /h)	9.1	10.9	12.0
Water Pressure Drop (kPa)	29	32	35
Water Pipe Connection (mm)	48.3		
Noise Level at 1m [dB(A)]	45~56	45~57	45~58
Net Dimensions [L*W*H (mm)]	1192*447*775		
Net Weight (kg)	66	71	73
<b><i>The above data are for reference only, the specific data are subject to actual product.</i></b>			

### 3. INSTALLATION AND CONNECTION

**⚠ WARNING:** The heat pump must be installed by a professional team. The users are not qualified to install by themselves, otherwise the heat pump might be damaged and risky for users' safety.

This section is provided for information purposes only and must be checked and adapted if necessary according to the actual installation conditions.

#### 3.1. Transportation

1. When storing or moving the heat pump, the heat pump should be at the upright position.

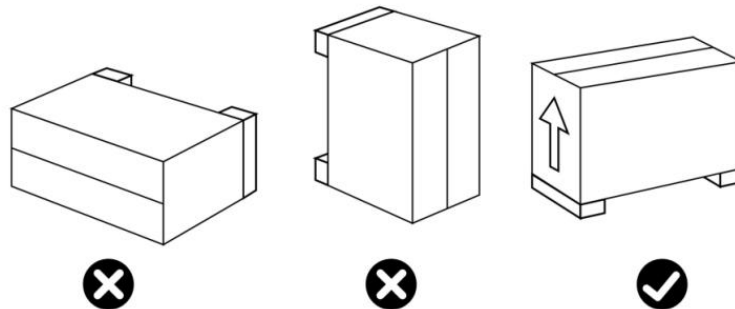

2. When moving the heat pump, do not lift the water union since the titanium heat exchanger inside the heat pump will be damaged.

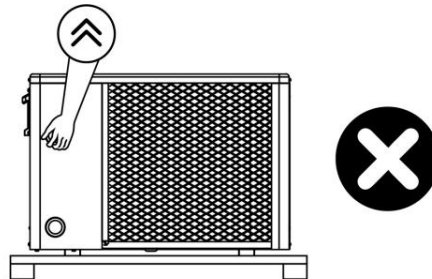

#### 3.2. Notice Before Installation

1. The inlet and outlet water unions can't bear the weight of soft pipes. The heat pump must be connected with hard pipes!

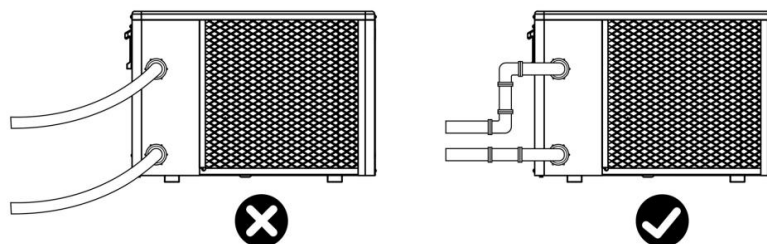

2. In order to guarantee the heating efficiency, the water pipe length should be  $\leq 10$  m between the pool and the heat pump.

### 3.3. Installation Instruction

#### 3.3.1 Pre-requirements

**Equipment necessary for the installation of your heat pump:**

- ① Power supply cable suitable for the unit's power requirements.
- ② A By-Pass kit and an assembly of PVC tubing suitable for your installation as well as stripper, PVC adhesive and sandpaper.
- ③ A set of wall plugs and expansion screws suitable to attach the unit to your support.
- ④ It is recommended to connect the unit to the installation by means of flexible PVC pipes in order to reduce the transmission of vibrations.
- ⑤ Suitable fastening studs may be used to raise the unit.

#### 3.3.2 Heat Pump Installation

- ① The frame must be fixed by bolts (M10) to concrete foundation or brackets. The concrete foundation must be solid; the bracket must be strong enough and anti-rust treated;
- ② The heat pump needs a water pump (Supplied by the user). The recommended pump specification-flux: refer to technical parameter, Max. lift  $\geq 10\text{m}$ ;
- ③ When the heat pump is running, there will be condensation water discharged from the bottom, please pay attention to it. Please insert the drainage tube(accessory) into the hole and clip it well, then connect a pipe to drain off the condensation water.
- ④ When installing the heat pump, raise it at least 10cm with solid water-resistant pads

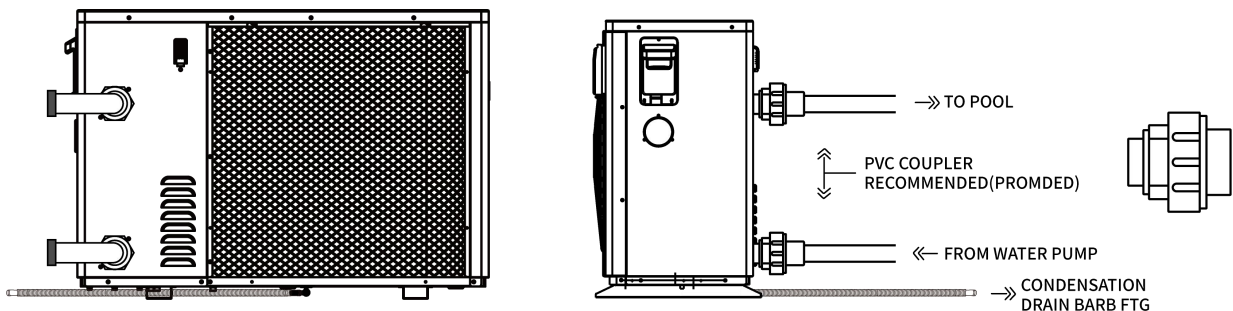

#### 3.3.3 Location and Space

Please comply with the following rules concerning the choice of heat pump location.

- ① The unit's future location must be easily accessible for convenient operation and maintenance.
- ② It must be installed on the ground, fixed ideally on a level concrete floor. Ensure that the floor is sufficiently stable and can support the weight of the unit.
- ③ A water drainage device must be provided close to the unit in order to protect the area where it is installed.
- ④ If necessary, the unit may be raised by using suitable mounting pads designed to support its weight.
- ⑤ Check that the unit is properly ventilated, that the air outlet is not facing the windows of neighbouring buildings and that the exhaust air cannot return. In addition, provide sufficient space around the unit for servicing and maintenance operations.

- ⑥ The unit must not be installed in an area exposed to oil, flammable gases, corrosive products, sulphur compounds or close to high frequency equipment.
- ⑦ To prevent mud splashes, do not install the unit near a road or track.
- ⑧ Please ensure the unit is installed in an appropriate location to avoid causing a nuisance to neighbors.
- ⑨ Keep the unit as much as possible out of the reach of children.
- ⑩ Installation space: Unit: mm

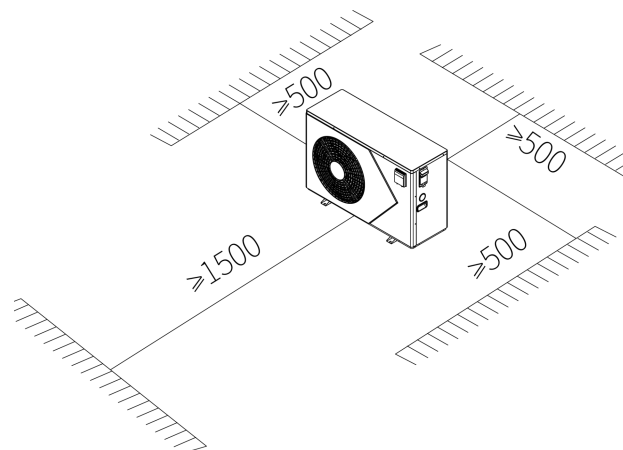

Leave more than 1 meter space in front of the heat pump.  
 Leave 500 mm of empty space on the sides and 300 mm of empty space on the back of the heat pump and free ventilation above  
 Do not leave any obstacles above or in front of the device!

### 3.3.4 Installation Layout

Notice: The filter must be cleaned regularly to ensure that the water in the system is clean and avoid blocking of filter. It is necessary that drainage valve is fixed on the lower water pipe. If the unit is not running during winter months, please disconnect power supply and let out drain water from unit through drainage valve. If ambient temperature of running unit is below 0 °C , please keep water pump running.

The installation diagram is shown in the following figure:

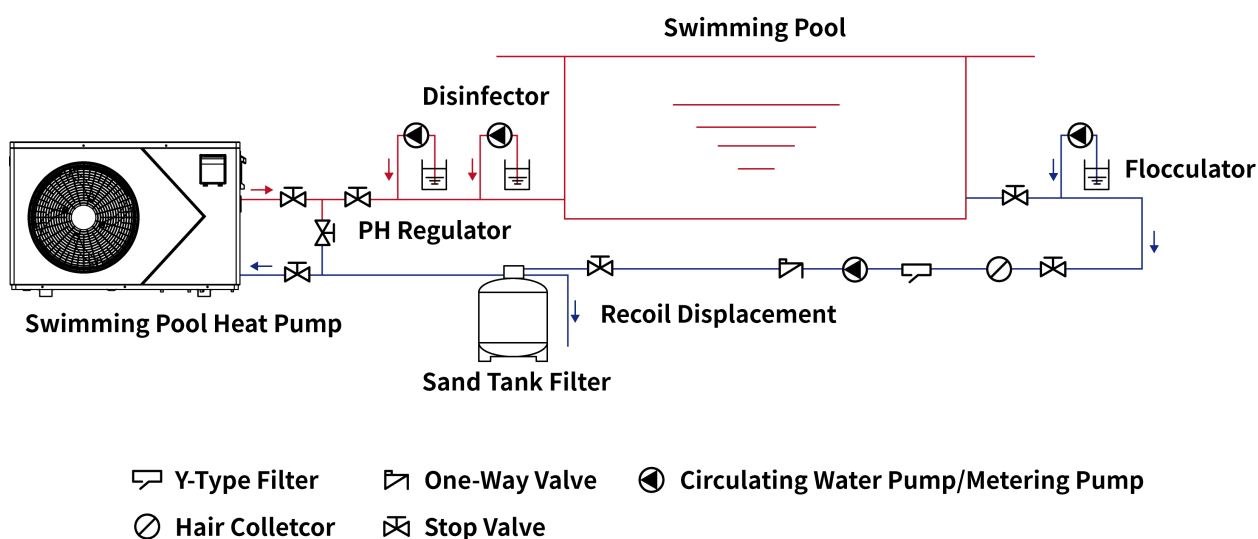

No.	Item	Quantity	No.	Item	Quantity
①	Swimming Pool Heat Pump	1	⑦	PH Regulator	1
②	Y-Type Filter	1	⑧	Sand Tank Filter	1
③	One-Way Valve	1	⑨	Flocculator	1
④	Circulating Water Pump	1	⑩	Disinfectant	1
⑤	Hair Collector	1	⑪	Metering Pump	3
⑥	Stop Valve	7			

### 3.3.5 Electrical Installation

To function safely and maintain the integrity of your electrical system, the unit must be connected to a general electricity supply in accordance with the following regulations:

- ① Upstream, the general electricity supply must be protected by a 30mA differential switch.
- ② The heat pump must be connected to a suitable D-curve circuit breaker in accordance with current standards and regulations in the country where the system is installed.
- ③ The electricity supply cable must be adapted to match the unit's rated power and the length of wiring required by the installation. The cable must be suitable for outdoor use.
- ④ For a three-phase system, it is essential to connect the phases in the correct sequence. If the phases are inverted, the heat pump's compressor will not work.
- ⑤ In places open to the public, it is mandatory to install an emergency stop button close to the heat pump.

Model	Power Supply Wires		
	Electricity Supply	Cable Diameter	Specification
Nova V2 - 09	220-240V~50Hz	1mm <sup>2</sup>	18AWG
Nova V2 - 15	220-240V~50Hz	1.5mm <sup>2</sup>	14AWG
Nova V2 - 18	220-240V~50Hz	2.5mm <sup>2</sup>	12AWG
Nova V2 - 21	220-240V~50Hz	2.5mm <sup>2</sup>	12AWG
Nova V2 - 25	220-240V~50Hz	4mm <sup>2</sup>	10AWG
Nova V2 - 28	220-240V~50Hz	4mm <sup>2</sup>	10AWG

### 3.3.6 Electrical Connection

**⚠ WARNING:** Power supply of heat pump must be disconnected before any operation. Please comply with the following instruction to connect heat pump.

Step 1: Detach electrical box cover by a screwdriver to access electrical terminal block.

Step 2: Insert cable into heat pump unit port.

Step 3: Connect power supply cable to terminal block according to the diagram below.

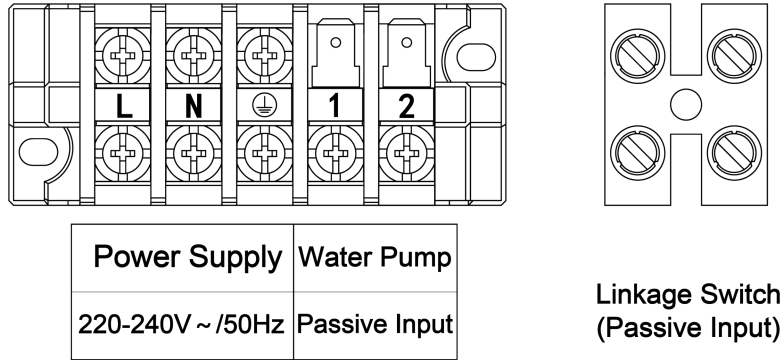

Nova V2 - 09/ Nova V2 - 15/ Nova V2 - 18/ Nova V2 - 21/ Nova V2 - 25/ Nova V2 - 28

### 3.4. Trial Running After Installation

**⚠ WARNING:** Please check all the wiring carefully before turning on the heat pump.

#### 3.4.1. Inspection Before Trial Running

Before running test, confirm below items and write √ in block;

<input type="checkbox"/>	Correct unit installation
<input type="checkbox"/>	Power supply voltage is the same as unit rated voltage
<input type="checkbox"/>	Correct piping and wiring
<input type="checkbox"/>	Air inlet & outlet of unit is unblocked
<input type="checkbox"/>	Drainage and venting is unblocked and no water leaking
<input type="checkbox"/>	Leakage protector is working
<input type="checkbox"/>	Piping insulation is working
<input type="checkbox"/>	Ground wire is connected correctly

#### 3.4.2. Trial Running

Step 1: Running test can begin after completing all installation;

Step 2: All wiring and piping should be connected well and carefully checked, then fill water tank with water before power is switched on;

Step 3: Emptying all air within pipes and water tank, press “ON-OFF” button on control panel to run the unit at setting temperature;

Step 4: Items need to be checked during running test:

- ① During the trial running, unit current is normal or not;
- ② Each function button on wire controller is normal or not;
- ③ Display screen is normal or not;
- ④ Are there any leakage in the whole heating circulation system;
- ⑤ Condensate drain is normal or not;
- ⑥ Are there any abnormal sound or vibration during running?

## 4. WIRE CONTROLLER OPERATION GUIDANCE

### 4.1. Wire Control Panel Diagram

- Main Interface (Heating Mode)

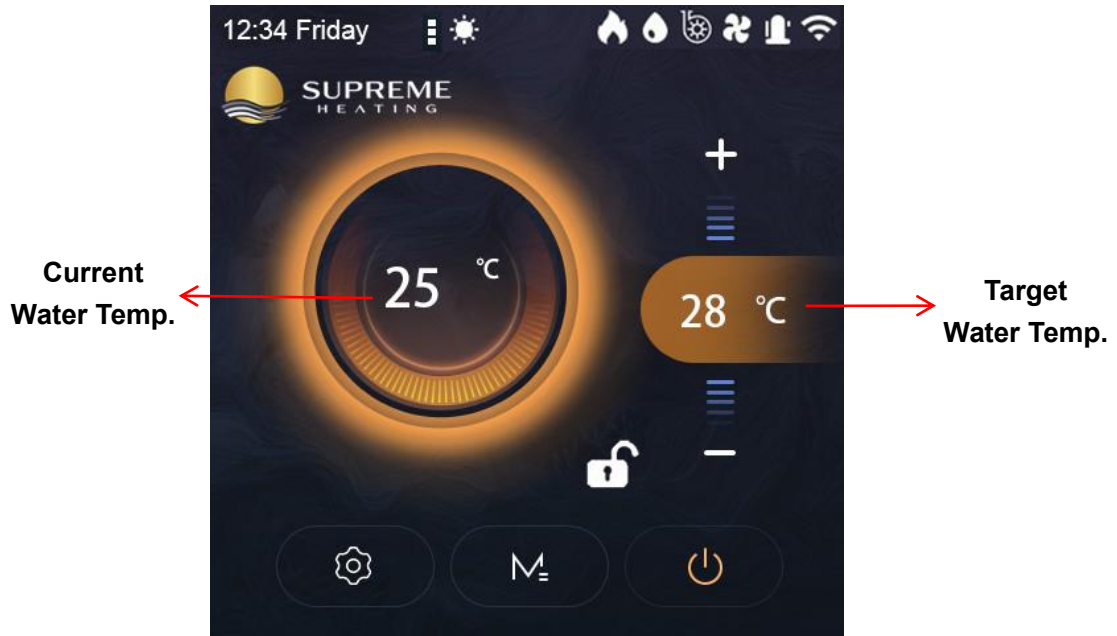



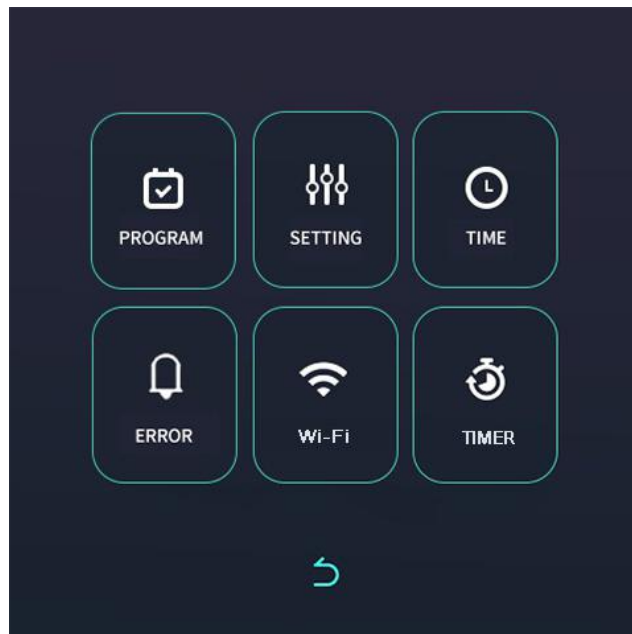





















- Menu



































● Icon

No.	Name	Icon	No.	Name	Icon
1	Lock Status		13	Compressor	
2	Unlock Status		14	Wi-Fi	
3	Heating Mode		15	ON/ OFF	
4	Cooling Mode		16	Mode	
5	Auto. Mode		17	Menu	
6	Silent Mode		18	Up	
7	Smart Mode		19	Down	
8	Powerful Mode		20	Return	
9	Defrosting		21	Next Page	
10	Water Pump		22	Previous Page	
11	Fan Motor		23	Function OFF	
12	Anti-freeze		24	Function ON	

## 4.2. Key Operating Instruction

NO.	Item	Operation Guide
1	Lock/unlock	1) If the main interface shows icon “  ”, press this key to unlock; 2) If the main interface shows icon “  ”, press this key to lock; 3) In any interface, if there is no key operation for 60 seconds, the system will automatically go back to the main interface and enter lock status;
2	ON/ OFF	In unlocked status, press icon “  ” to switch on/off;
3	Mode setting	<ul style="list-style-type: none"> <li> <b>Heating/Cooling/Auto. Mode:</b>                In power-on status, press icon “” to switch the mode: Heating, Cooling and Auto. Mode:   <b>Notice: The main interface shows different colors in different mode (Heating-Orange, Cooling-Green, Auto.-Red), and the corresponding mode icon is shown at the top of the main interface.</b> </li> <li> <b>Silent/Smart/Powerful Mode:</b>                In power-on status, press icon “” for 3 seconds to switch the Silent/ Smart/ Powerful Mode.                (The corresponding mode icon is shown at the top of the main interface)             </li> </ul>
4	Time setting	In unlocked status, short press icon “  ” to enter the menu, then press “  ” to set the system time, and then press the number for hour and minute change the time.
5	Timer setting	In unlocked status, press icon “  ” to enter the menu, then press “  ” to set the timer, press icon “  ” or “  ” to activate and cancel the timer, and then press the number for hour and minute to set the timer. On the timer setting interface, there are 2 timers in each group, the upper one is switch-on time, and the other one is shutdown time.

NO.	Item	Operation Guide
6	Parameter query	In unlocked status, press icon "  " to enter the menu, then press "  " to enter the interface of parameter query, and then press "  " and "  " to check the parameters;
7	Parameter setting	In unlocked status, press icon "  " to enter the menu, then press "  " to enter the password interface, input the password and then press "  " to enter the parameter setting interface and change the parameter you want.
8	Faulty history	In unlocked status, press icon "  " to enter** the menu, then press "  " to enter the historic error interface, then the corresponding error code with the specific time (based on the time of the wire control system) will show up;  In historic error interface, press icon "  " for 2 seconds to clear all historical fault records;
9	Wi-Fi connection	In unlocked status, press icon "  " to enter the menu, then press "  " to enter the Wi-Fi connection interface, and then press "  " to activate the Wi-Fi configuration;
10	Forced defrosting	In heating mode status, press icon "  " to enter the menu, then press "  " for 3 seconds, the buzzer will ring 2 times, and the unit will be forced to enter defrosting mode.
11	Celsius and Fahrenheit	In unlocked status, press icon "  " for 3 seconds, the buzzer will ring 2 times then the temp. unit will change from °C (°F) to °F (°C) automatically.
12	Parameter reset	In unlocked status, press icon "  " to enter the menu, then press "  " to enter the password interface, input the password to enter the parameter list, press icon "  " for 1 second, the buzzer will ring 3 times to reset the parameters;

### 4.3. System Status Parameter Query

Code	Description	Code	Description
A01	Water Inlet Temp.	A09	Reserved
A02	Water Outlet Temp.	A10	Compressor Current
A03	Ambient Temp.	A11	Heatsink Temp.
A04	Exhaust Temp.	A12	DC Bus Voltage
A05	Suction Temp.	A13	Compressor Frequency
A06	Heating Coil Temp.	A14	DC Fan Speed
A07	Cooling Coil Temp.	A15	Main Control Board Version
A08	EEV Steps		

#### 4.3.1. Error code list

In the running process, the unit may be faulted if the following code is displayed, please turn off power switch of the unit and turn on power switch of unit again after 30 seconds. If the code is no longer displayed, that means the unit could be used again. If the code is displayed again, please contact our company for trouble shooting!

- **System error code**

Code	Description	Code	Description
Er03	Water flow protection	Er20	Inverter module protection
Er04	Anti-freeze protection	Er21	Ambient temp. sensor fault
Er05	High pressure protection	Er23	Low outlet water temp. protection when cooling
Er06	Low pressure protection	Er27	Water outlet temp. sensor fault
Er09	Communication fault between PCB & display	Er28	Ct over current protection
Er10	Communication fault of inverter module	Er29	Suction temp. sensor fault
Er12	High exhaust temp. protection	Er32	High outlet water temp. protection when heating
Er15	Water inlet temp. sensor fault	Er33	High coil temp. protection when heating
Er16	Coil temp. sensor fault when heating	Er42	Coil temp. sensor fault when cooling
Er18	Exhaust temp. sensor fault	Er44	Min. working ambient temp.
Er19	DC fan motor fault		

E20 fault will display the following error codes at the same time, the error codes will switch every 3 seconds. Among them, error codes 1-128 appear in priority. When error codes 1-128 don't appear, then it will show error codes 257-384 . If two or more error codes appear at the same time, then display error codes accumulation. For example, 16 and 32 occur at the same time, it will show 48.

- **Driver module error list**

Code	Description	Code	Description
1	Compressor Over-current	258	AC phase loss or CT is disconnected
2	Compressor out of step	260	AC over-current or compressor overpower
8	Compressor phase loss	288	IPM over heat protection
16	DC voltage is too low	320	Compressor current protection
32	DC voltage is too high	384	PFC module over heat protection
257	Communication is abnormal		

## 4.5. Wi-Fi Settings

### 4.5.1 Software Installation

- ① Method 1: Search "Smart Life" in your APP store ,install "🏠".Click "GET" to install.

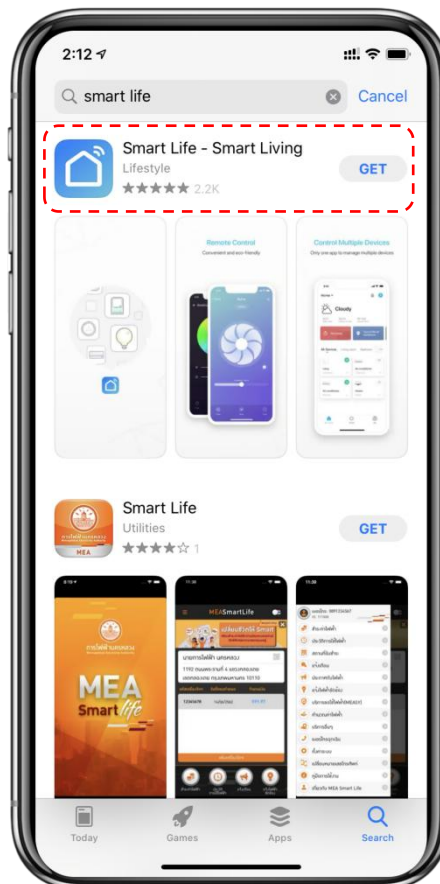

② Method 2: Scan the QR code.







For IOS and Android Users

### 4.5.2 Software Startup

After installation,click “” on your desktop to start up Smart Life.

### 4.5.3 Software Registration and Configuration

#### 1. Registration

① Users don't have account can click “Register” to create an account: Register  Enter your phone number  Get Verification Code  Enter Verification Code  Set Code;

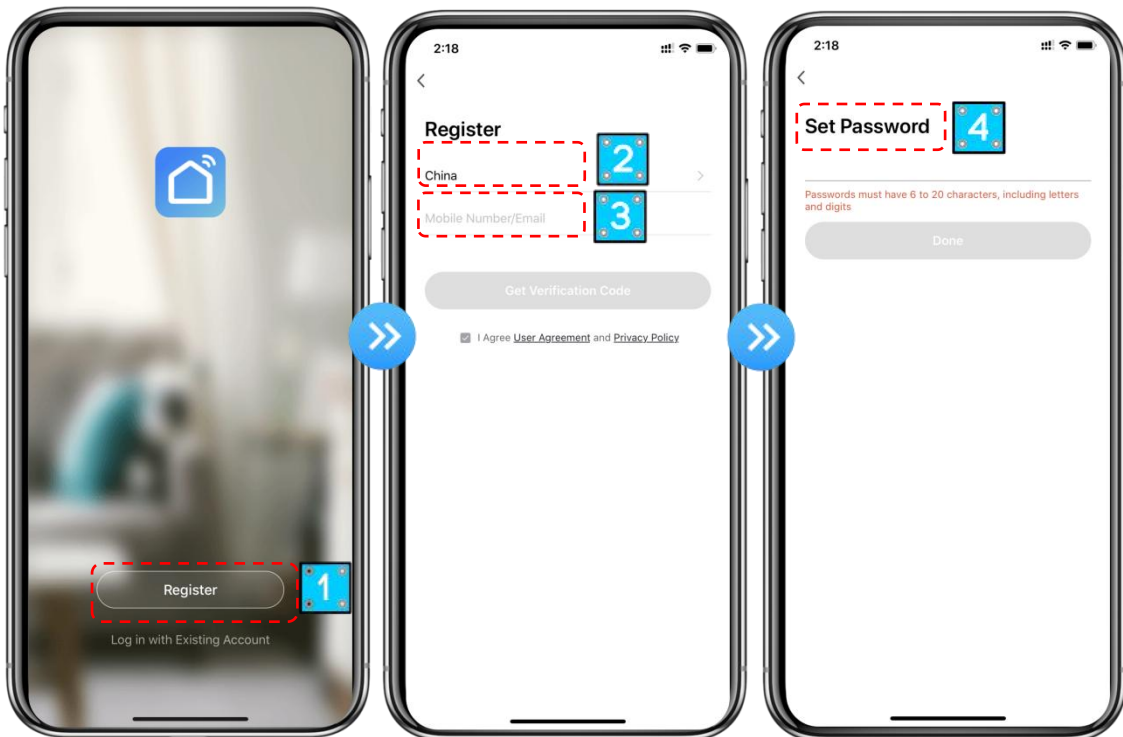

② After registration, you need to Create a Home: Create a Home → Set Home Name → Set Home Location → Add Rooms.

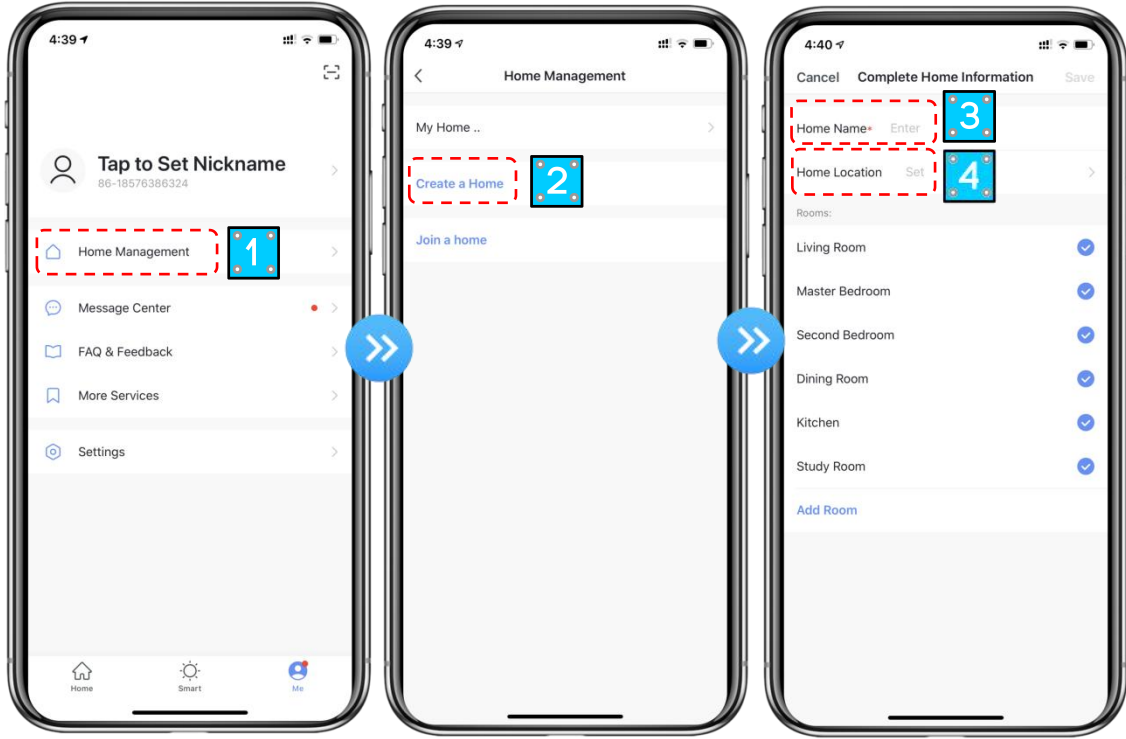

## 2. Account ID+ Password Login

- ① Existing accounts can be logged in directly, in the following order.

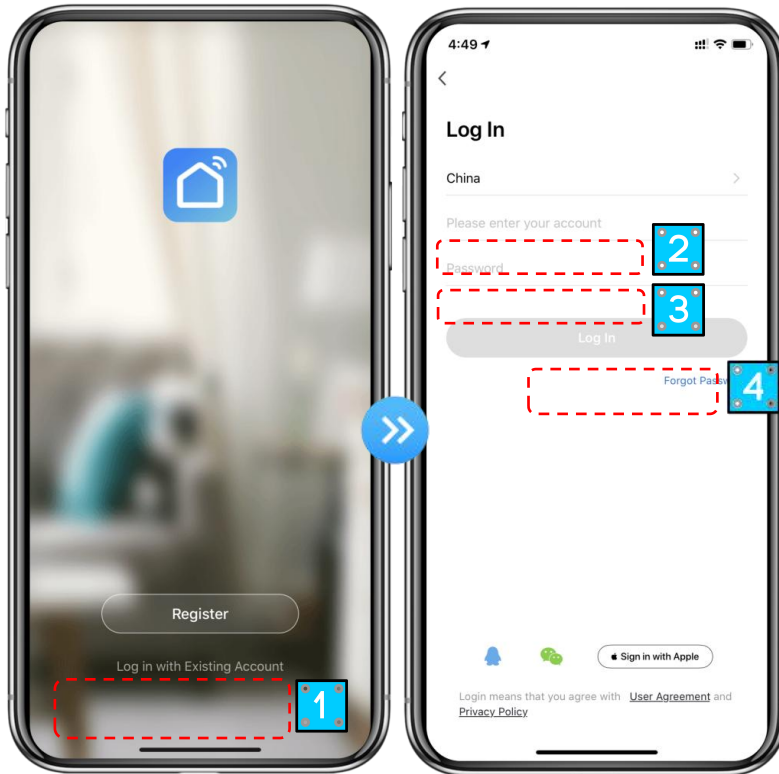

- ② If you forget your password you can choose to login with your verification code and select "Forgot Password": Enter your phone number → Get verification code .

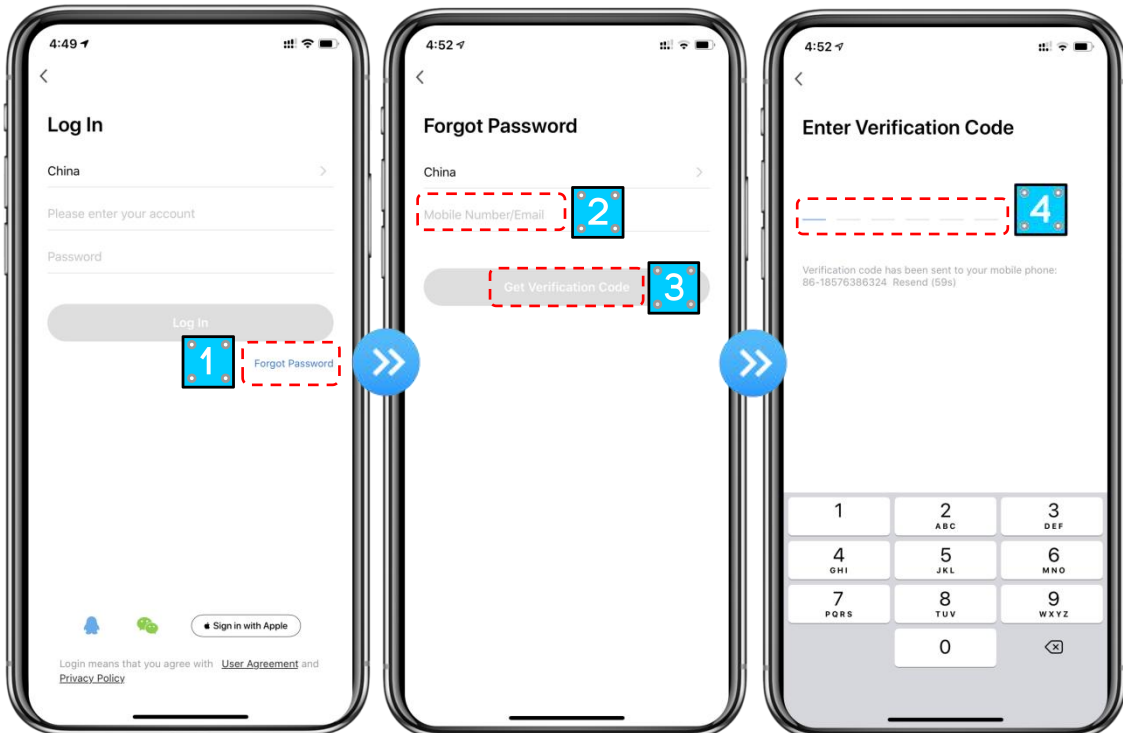



③ After creating a home or logged in, enter the main interface of APP.





**Note:**

Click the device to check the status, and you can set the operating mode, ON/OFF, timer.  
Click “+” to add devices.

### 3. Wi-Fi Module configuration steps:

#### Step 1:

In unlocked status, press icon “” to enter the menu, then press “” to enter Wi-Fi connection interface, and then press “**REENTER**” to activate the Wi-Fi configuration;

#### Step 2:

Turn on the phone's Wi-Fi function and connect to the Wi-Fi hot-spot. The Wi-Fi hot-spot must be able to connect to the Internet normally;

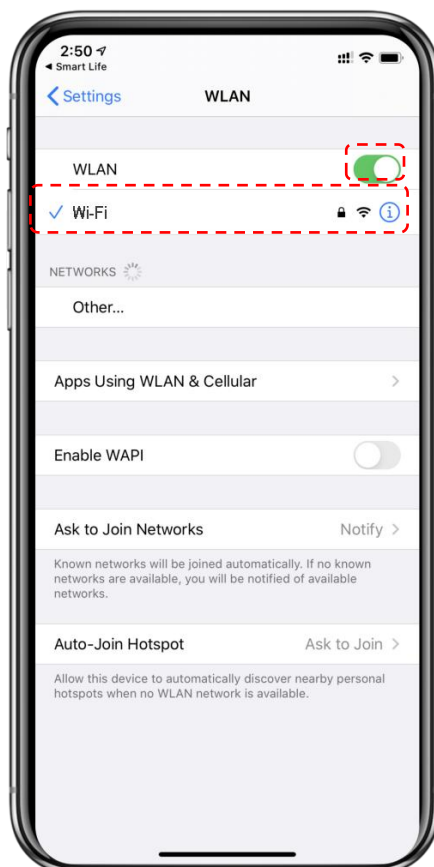

### Step 3:

Open the "smart life" APP, log in into the main interface, click on the top right corner "+" or "add equipment" of the interface, enter the equipment type selection, the "Large Home Appliances", select "Smart Heat Pump" equipment and add equipment into the interface.

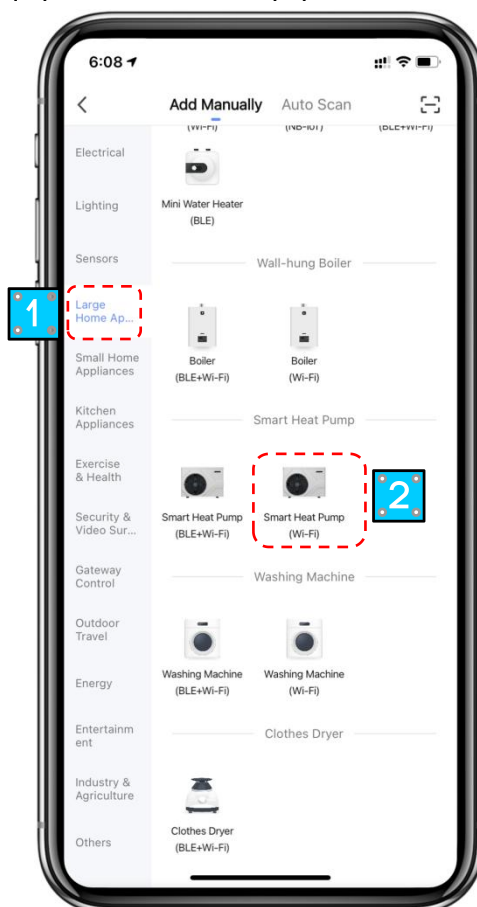

### Step 4:

After selecting "Smart Heat Pump", enter the interface of "Add Equipment", . After the indicator light under "  " flashes rapidly , click" Confirm indicator rapidly blink ".

Enter the Wi-Fi connection interface, enter the Wi-Fi password of the mobile phone (it must be the same as the Wi-Fi of the mobile phone), click "Next", and then directly enter the connected status of the device.

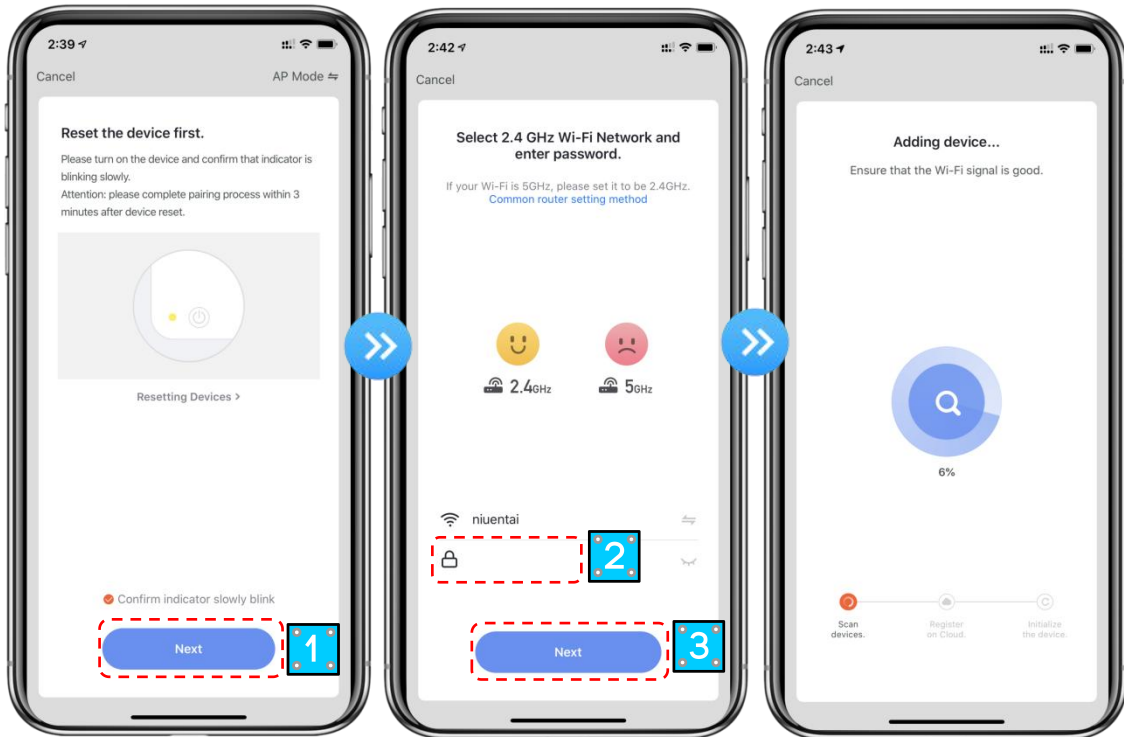

**Step 5:**

When “Scan devices”, “Register on Cloud”, “Initialize the device” are all completed, connect succeeds.

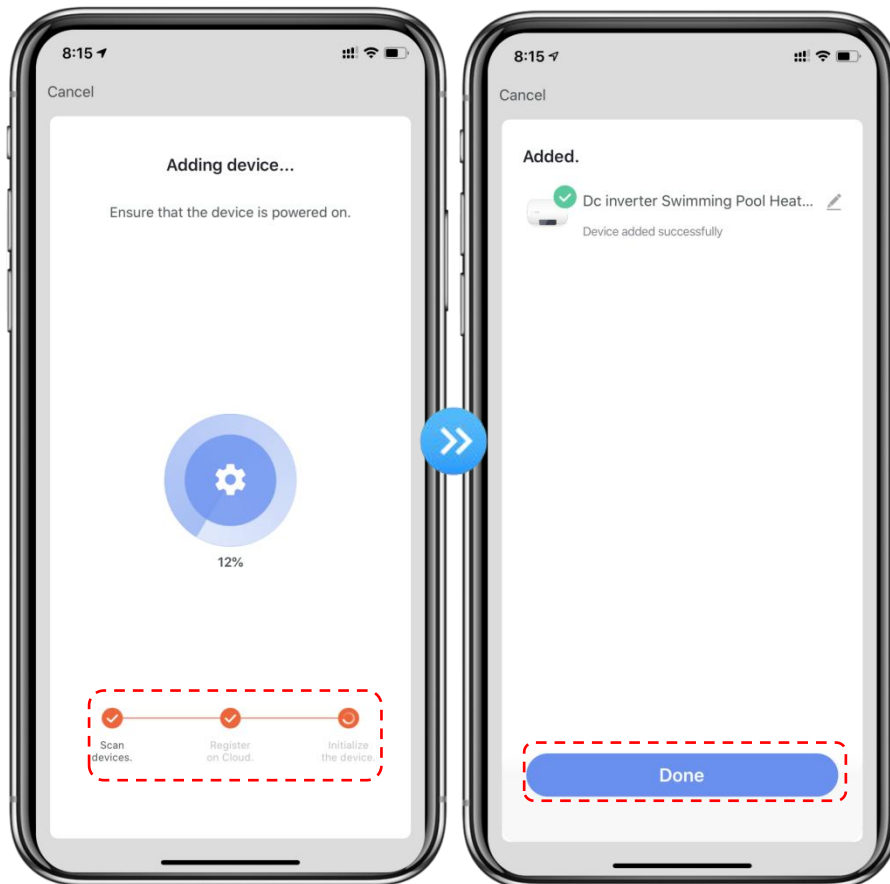

#### 4.5.4 Software Function Operation

- After the device is bound successfully, enter the operation interface of “Smart heat pump” (Device name, modifiable)
- In the main interface of “Smart Life”, click “Smart heat pump” to enter the operation interface.



- ① Back
- ② Edit: You can change device name, select device installation location, check networking status, add shared users, create device cluster, view device information, and more.
- ③ Setting temp. adjustment: The circle slides counterclockwise to reduce the temp., but clockwise to increase the temp..
- ④ Target temp.
- ⑤ Current temp.
- ⑥ ON/OFF
- ⑦ Mode switching: Click to select the mode to be switched.
- ⑧ Setting: Click to add timer OFF/ON time.

● **Modify device name**

Click in the following order to enter device details, and click "Device Name" to rename the device.

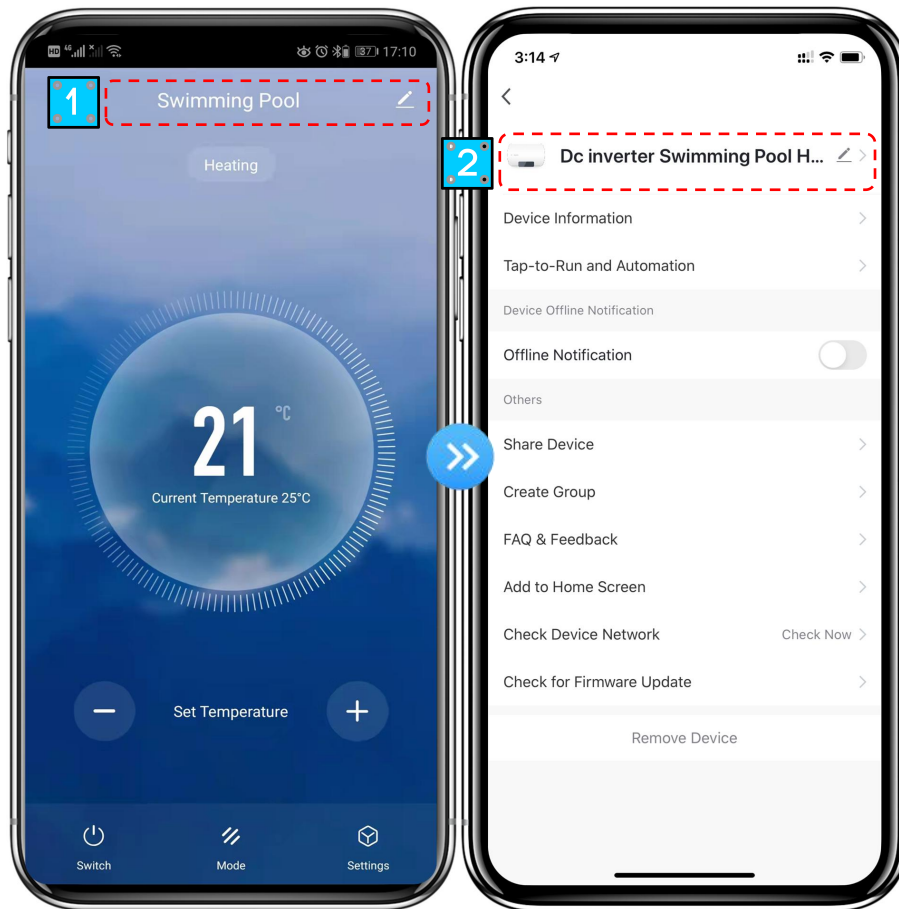

● **Device sharing**

- ◆ To share a bound device, the user should do so in the following order.
- ◆ After successful sharing, the list will be added to show the person shared
- ◆ If you want to delete the account you shared to, cross the selected account to the left, and delete it.
- ◆ The user interface is as follows.

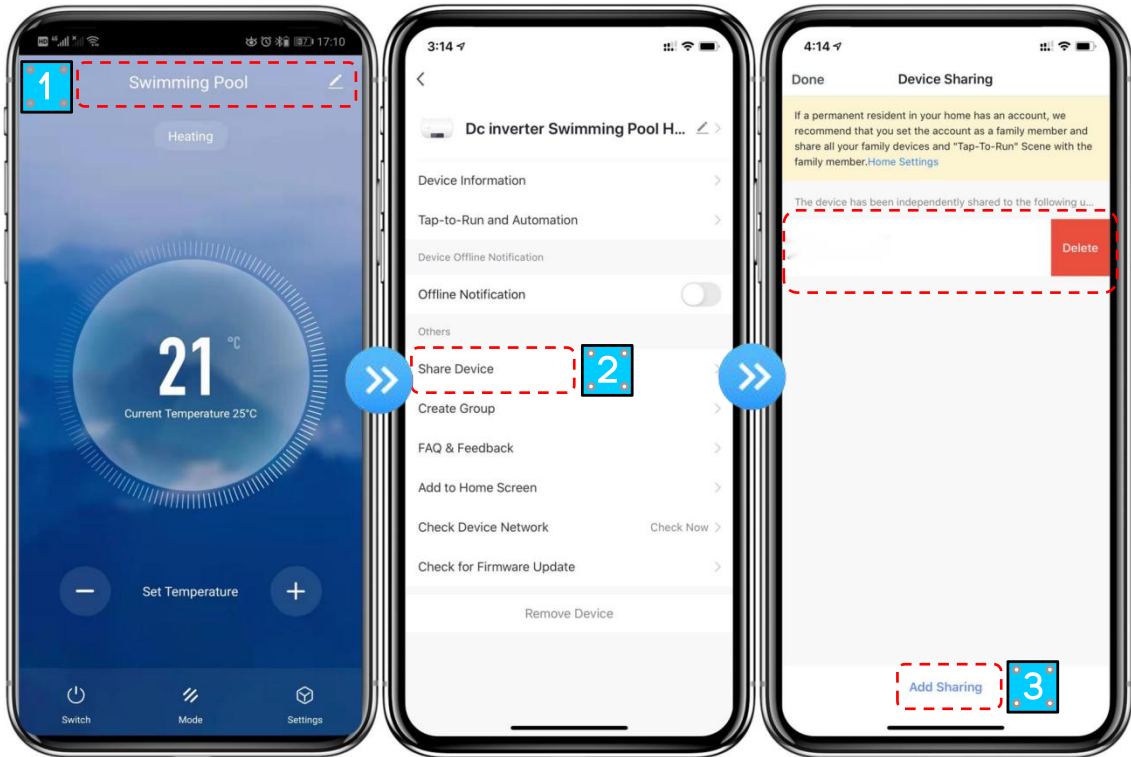

- ◆ Enter the account of the shared, click "Done", and the share success list shows the newly added account of the Shared.

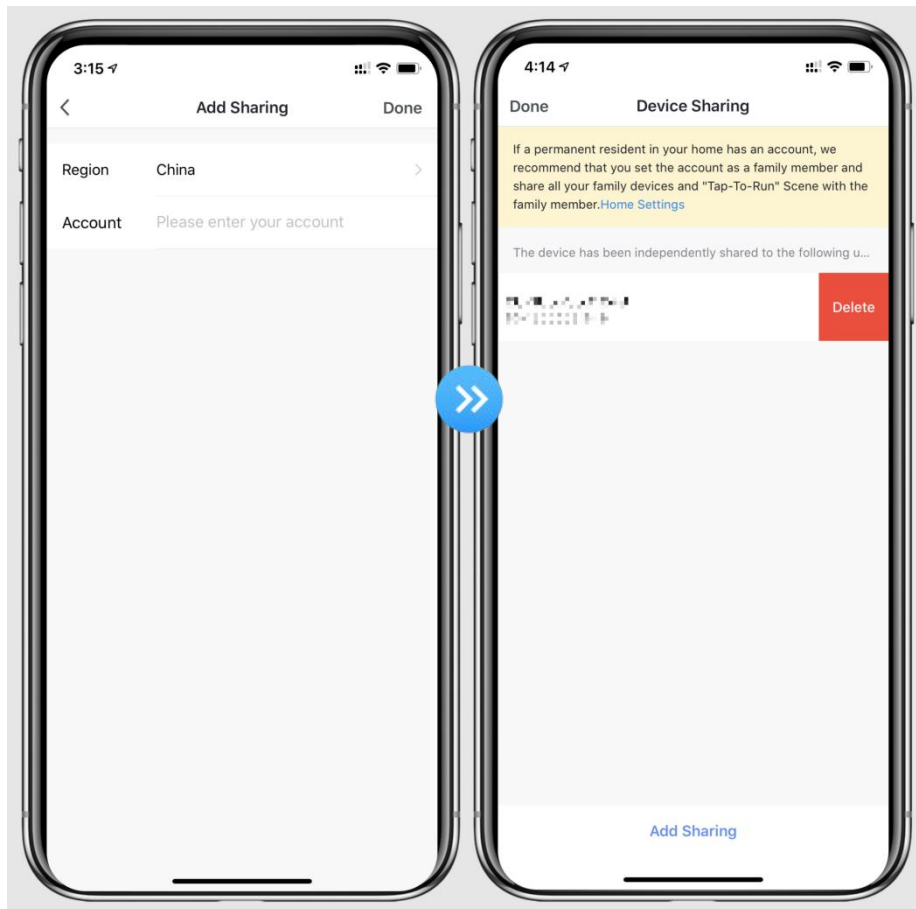

- ◆ The interface of the person to be shared is as follows. The received shared device is displayed. Click it to operate and control the device.



- **Mode settings**

Click “” on the main interface to switch the modes.

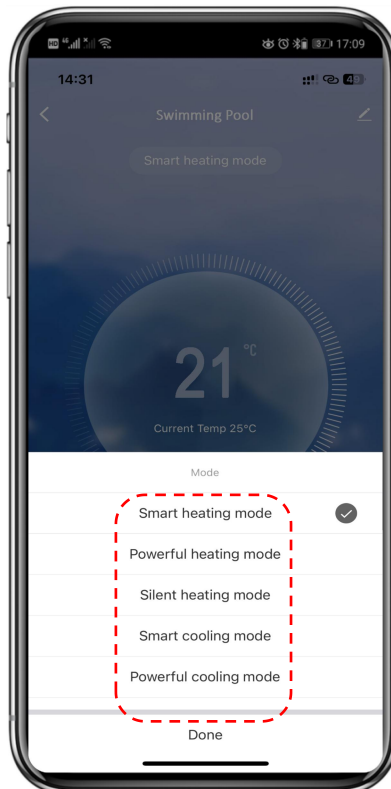



● **Timer setting**

1. Click “” on the main interface to enter the setting interface, then click “Timer” to add timer.

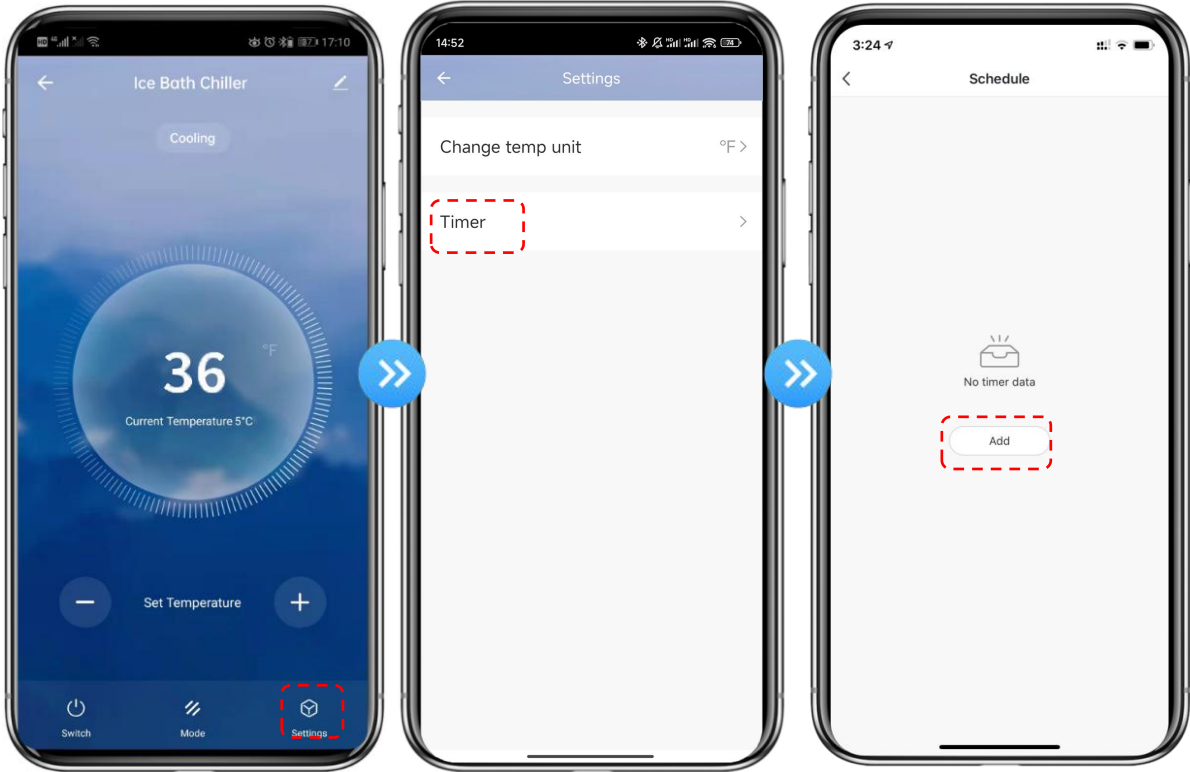

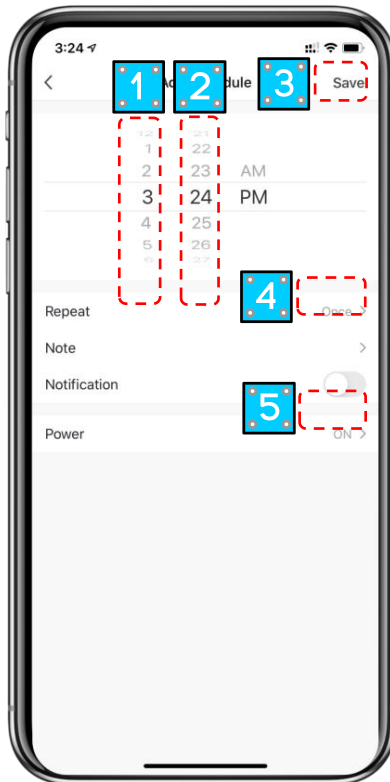

1. After entering timer setting, swipe up/down to set timer, set up repeat weeks and ON/OFF, then click “save” to save your settings as follows.



- ① Hours
- ② Minutes
- ③ Set the repetition
- ④ Set power ON/OFF
- ⑤ Save your modification

#### 4.5.5 Device Removal

Click “” on the top right corner of the main interface to enter the device details interface, and click “device removal”. Indicator light under “” flashes rapidly for 3 minutes, The network can be reconfigured within 3 minutes, and the network can be quit if it is not connected within 3 minutes. The specific operations are shown as follows.

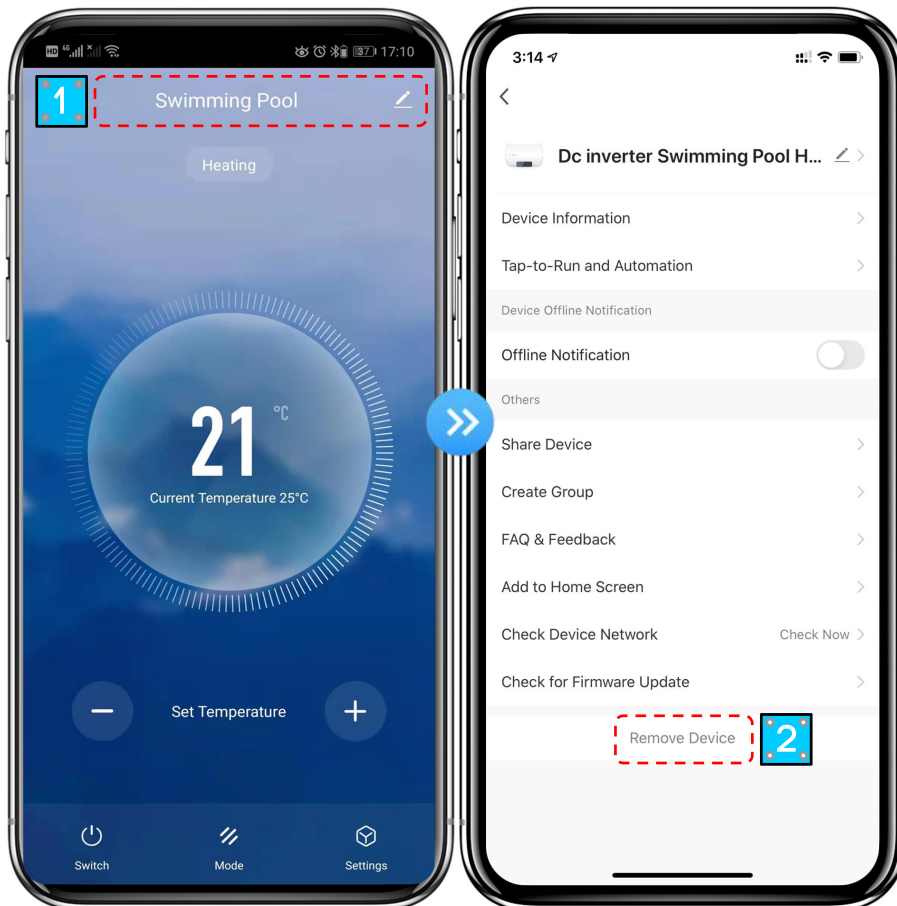

## 5. MAINTENANCE AND WINTERIZING

### 5.1. Maintenance

**⚠ WARNING:** Before undertaking maintenance work on the unit, ensure that you have disconnected the electrical power supply.

#### ● Cleaning

- a. The heat pump's casing must be cleaned with a damp cloth. The use of detergents or other household products could damage the surface of the casing and affect its properties.
- b. The evaporator at the rear of the heat pump must be carefully cleaned with a vacuum cleaner and soft brush attachment.

#### ● Annual maintenance

The following operations must be undertaken by a qualified person at least once a year.

- a. Carry out safety checks.
- b. Check the integrity of the electrical wiring.
- c. Check the earthing connections.
- d. Monitor the state of the pressure gauge and the presence of refrigerant.

### 5.2. Disassembly Guidelines

- ① Phillips screwdriver
- ② Flat-blade screwdriver

#### Step 1: Remove the junction box cover

- ① Remove the junction box cover screws;
- ② Take out the junction box cover in the direction of the arrow.

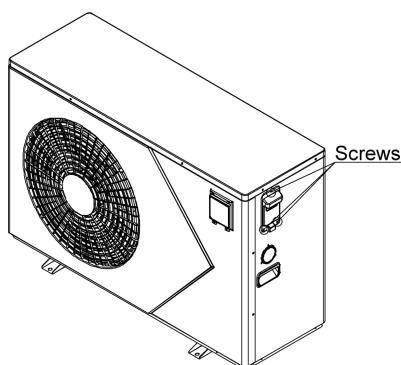

①

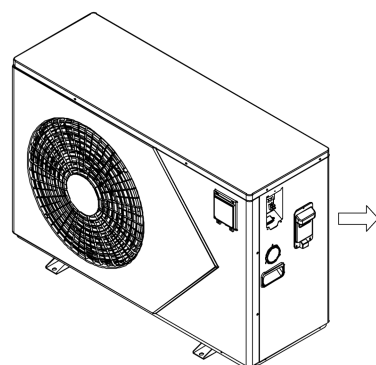

②

## Step 2: Remove the top cover

- ① Remove the screws on the top cover;
- ② Take out the top cover in the direction of the arrow.

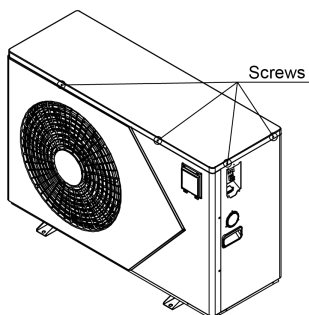

①

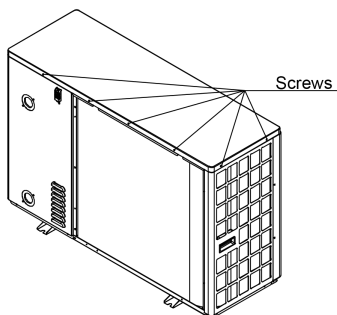

②

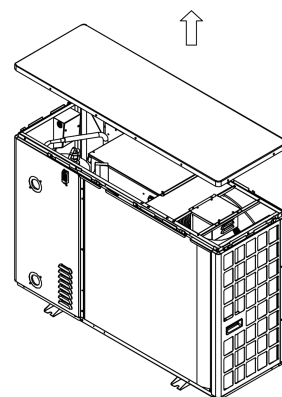

## Step 3: Remove the electrical box cover

The below tutorial image is for Nova V2 - 09/ Nova V2 - 15/ Nova V2 - 18/ Nova V2 - 25/ Nova V2 - 28

- ① Remove the screws on the electrical box cover;
- ② Take out the electrical box cover in the direction of the arrow.

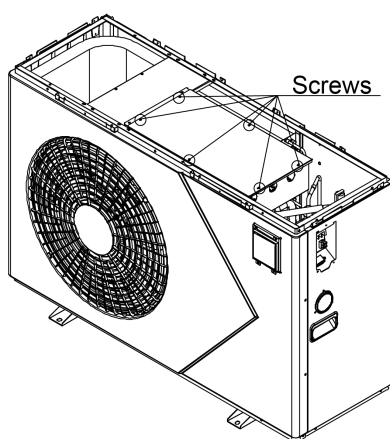

①

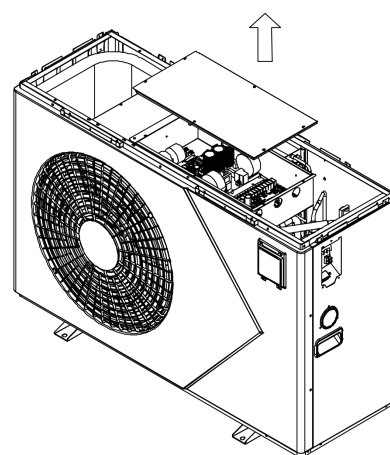

②

**The below tutorial image is for Nova V2 - 21**

- ① Remove the screws on the reactor box cover;
- ② Remove the screws on the electrical box cover;
- ③ Take out the electrical box cover in the direction of the arrow.

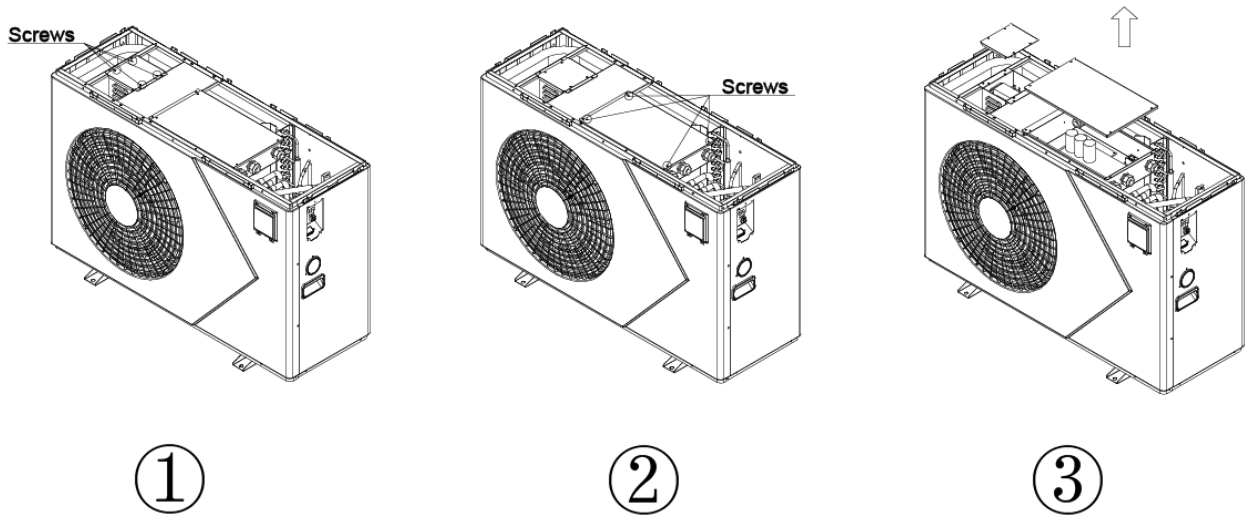

**Step 4: Remove the front panel**

- ① Remove the screws on the front panel;
- ② Take out the front panel in the direction of the arrow.

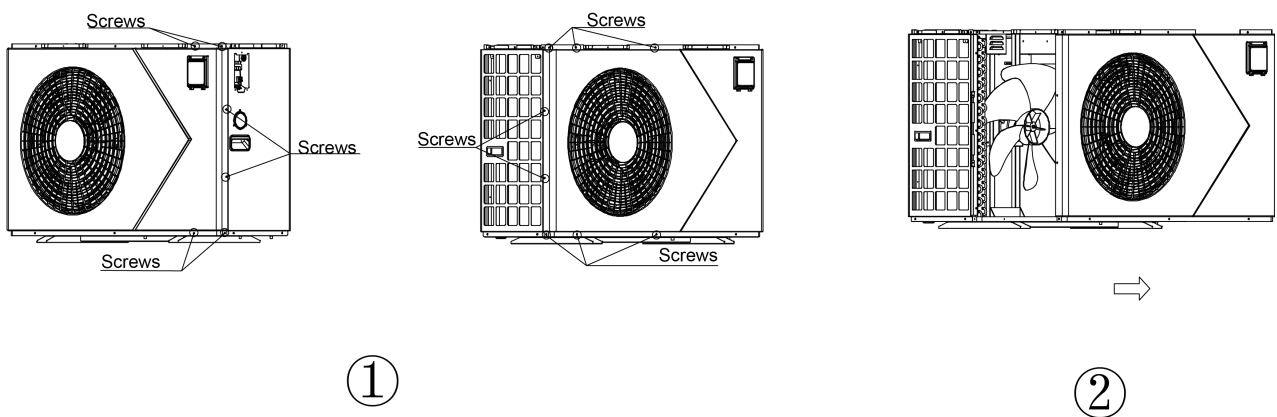

### Step 5: Remove the right panel

- ① Remove the screws on the fixing plate;
- ② Remove the screws of the pressure gauge, water inlet & outlet joint, and other screws on the right panel;
- ③ Take out the right panel in the direction of the arrow.

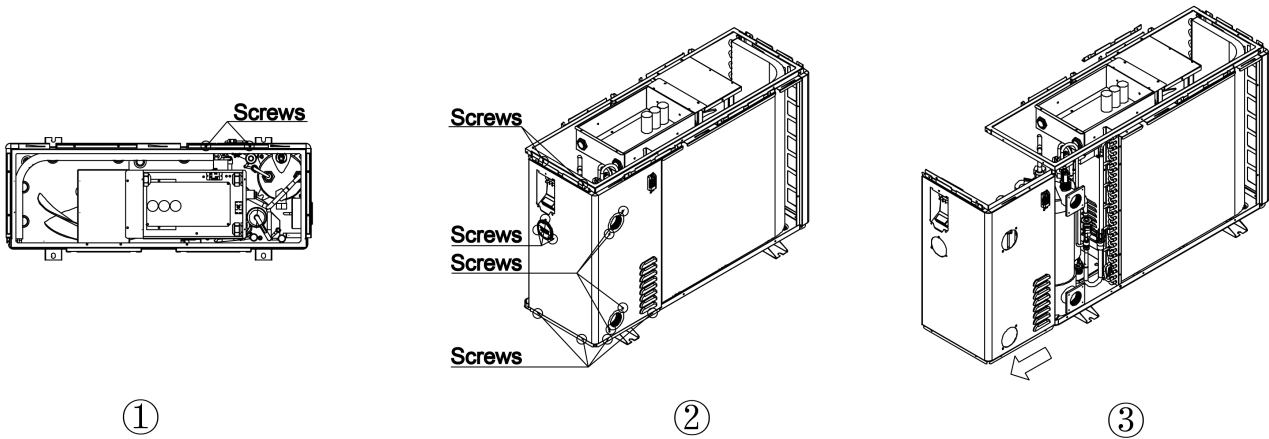

### Step 6: Remove the left panel

- ① Remove the screws on the left panel;
- ② Take out the left panel in the direction of the arrow.

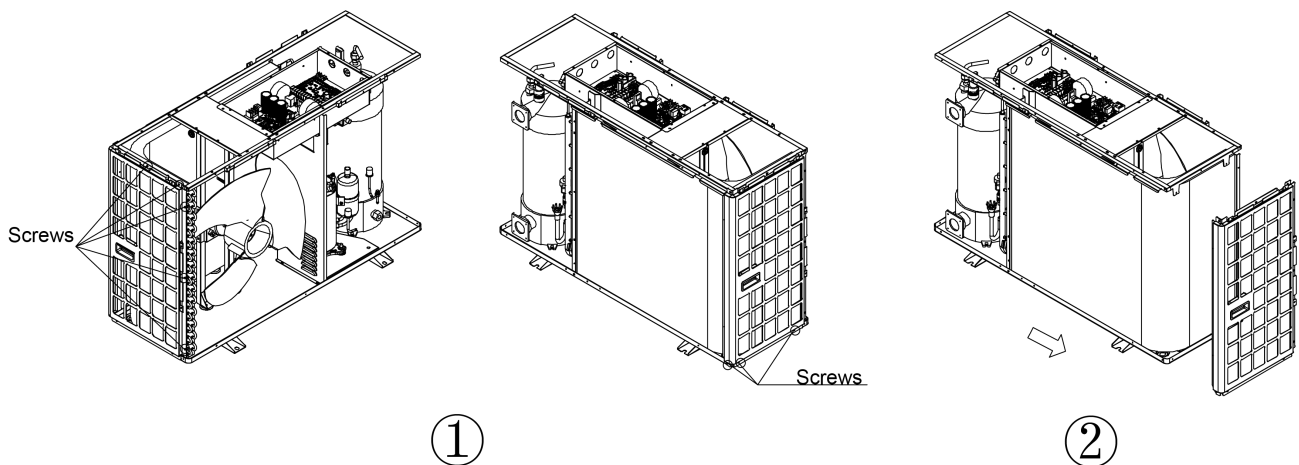

### 5.3. Winterizing



**“CUT OFF” power supply of the heater before cleaning, examination or repairing**

In winter season when you don't swim:

- a. Cut off power supply to prevent any machine damage.
- b. Drain water clear of the machine.

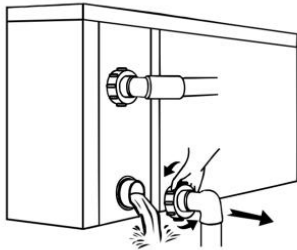

**⚠!! Important:**

Unscrew the water nozzle of inlet pipe to let the water flow out. When the water in machine freezes in winter season, the titanium heat exchanger may be damaged.

- c. Cover the machine body when not in use.

